

Huck PR 75

Quick Set Riveter For Plastic Rivets

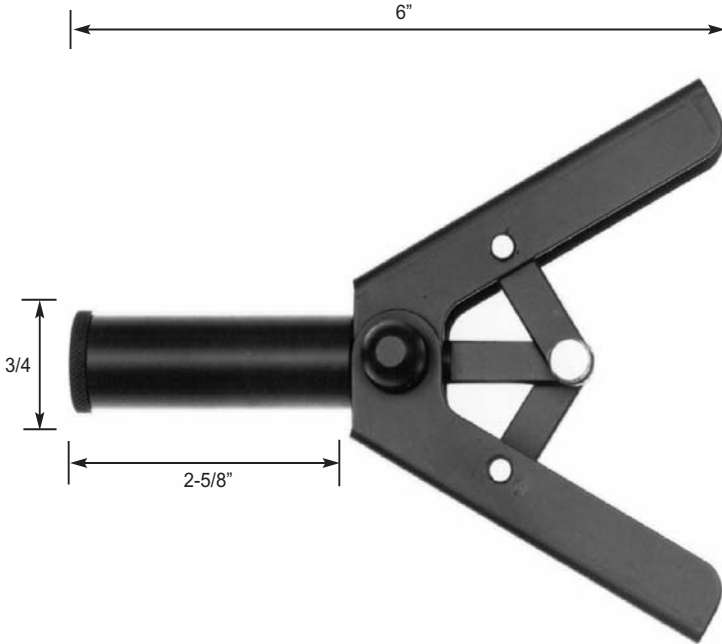

Competitive Advantages of the PR 75

- Sets all plastic rivets with one nosepiece and in a single stroke
- Plastic rivet manufacturers recommend the use of this tool over any other manual tool
- Sets the rivet properly every time with one straight pull. Does not bend the rivet stem causing premature breakage.
- Tool faces straight on to work surface
- Compound leverage arms



Alcoa Fastening Systems
Industrial Tools
Kingston Operations

1 Corporate Drive, Kingston, NY 12401
Tel: 800 431 3091, 845 331 7300
Fax: 845 334 7333

PR-75 RIVETER OPERATING INSTRUCTIONS

When using the PR-75 Riveter, snap the handles together sharply a couple of times to align the jaws. Next, insert rivet stem into tool and rivet body into workpiece. Squeeze the handles until rivet stem breaks from body. If rivet stem does not break, release the handles, regrip the stem, and squeeze handles until installation is complete. If rivet stem should become stuck in tool, point tool downward and snap handles together until stem drops out.

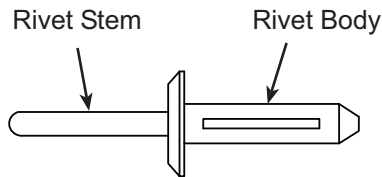

PR-75 RIVETER 90 Day Warranty

All Huck tools and parts have been carefully tested and checked at the factory and are guaranteed to be free from defects in material and workmanship, subject to the following conditions:

- A) PR-75 tools will be repaired free of charge or replaced at our discretion within 90 days of sale to the first user if, upon examination at our service center, we find a defect in material or workmanship.
- B) The tool must be returned intact and prepaid to the factory. Proof of date of sale must accompany any tool returned. This warranty will be void if repairs have been made or attempted by others, or if the tool has been subject to abuse, neglect, accident, or improper application.
- C) The foregoing obligation is Alcoa Fastening Systems' sole liability under this or any implied warranty, and no one is authorized to vary its terms or conditions.
- D) If you have any problems, please contact Customer Service at (800) 343-3633.



10-29-2010
HK1078

Alcoa Fastening Systems Industrial Products

5436 W 78th Street
Indianapolis, IN. 46268
800-343-3633

