



# Instruction Manual

# 2624 and 2630 series

## Hydraulic Installation Tools

**2624**  
**2624-15**

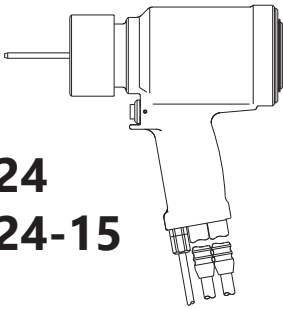

**2630**  
**2630RR**

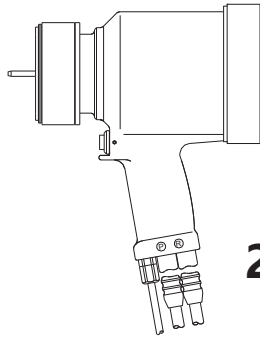

**2624HS**  
**2624-PT**

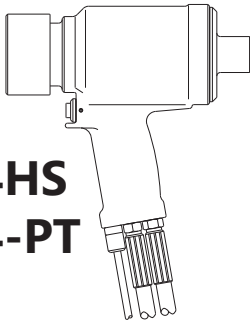

**2624PTD**

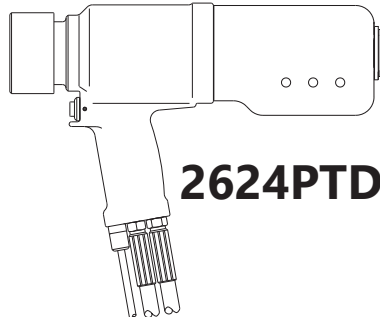

### Table of Contents

Declaration of Conformity	2
Safety Instructions	4-5
Specifications	6
Principle of Operation	7
Preparation for Use	7
Maintenance	8
Disassembly Instructions	9
Assembly Instructions	10
Components Drawings	11-15
Kits and Accessories	15
Sticker Locations	16
Troubleshooting	17



**HOWMET  
AEROSPACE**

## Declaration of Conformity

**Manufacturer:**

Huck International, LLC, Industrial Products Group, 1 Corporate Drive, Kingston, NY, 12401, USA

**Description of Machinery:**

Models 2600, 2620, 2624, 2630 family of hydraulic installation tools and specials based on their design (e.g. PR#####).

**Relevant provisions complied with:**

Council Directive related to Machinery (2006/42/EC)

Supply of Machinery (Safety) Regulations 2008

British Standard related to hand held, non-electric power tools (ISO 11148-2:2011)

**Representatives:**

UK: Paul Carson, Huck International, Ltd. Unit C Stafford Park 7, Telford Shropshire TF3 3BQ, England, United Kingdom

EU: Lutz Baumann, Hildesheim Operations, Fairchild Fasteners Europe - VSD GmbH, Steven 3, 31135, Hildesheim, Germany

**Authorized Signature/date:**

I, the undersigned, do hereby declare that the equipment specified above conforms to the above Directive(s) and Standard(s).

Signature: \_\_\_\_\_

Full Name: Nicholas Gougoutris

Position: Engineering Manager

Location: Huck International, LLC d/b/a Howmet Fastening Systems  
Kingston, New York, USA

Date: 11/02/2021 (November 2, 2021)



### Declared dual number noise emission values in accordance with ISO 4871

A weighted sound power level, LWA: **89** dB (reference 1 pW) Uncertainty, KWA: 3 dB

A weighted emission sound pressure level at the work station, LpA: **78** dB (reference 20 µPa) Uncertainty, KpA: 3 dB

C-weighted peak emission sound pressure level, LpC, peak: **119** dB (reference 20 µPa) Uncertainty, KpC: 3 dB

Values determined according to noise test code ISO 3744. The sum of a measured noise emission value and its associated uncertainty represents an upper boundary of the range of values which is likely to occur in measurements.

### Declared vibration emission values in accordance with EN 12096

Measured Vibrations emission value, a:	<b>.40</b> m/s <sup>2</sup>
Uncertainty, K:	<b>.02</b> m/s <sup>2</sup>
Values measured and determined according to ISO 28662-1, ISO 5349-2, and EN 1033	

Test data to support the above information is on file at:  
Howmet Fastening Systems, Kingston Operations, Kingston, NY, USA.



# DANGER - IMPORTANT

## DO NOT EXCEED HOSE MINIMUM BEND RADIUS

**Failure to heed the warnings below could lead to a damaged hose, damaged tool, damaged property, personal injury, or death.**

- This high pressure hose is not to be used other than assembled in a genuine HUCK tool or hose assembly or used as a replacement for the hose of a genuine HUCK tool or hose assembly.
- Improper use of this product can cause **property damage, personal injury, and death**, including but not limited to **electrocution, fluid injection** or **loss of limb** caused by **high pressure leak, dangerously whipping hose** or contact with suddenly moving or falling objects.
- Do not exceed rated working pressure (**700 bar/10150 psi**) or minimum bend radius (see chart below). Do not use in temperatures less than **-40°C (-40°F)** or greater than **+100°C (+212°F)**. Do not exceed fluid working temperature of **+70°C (+158°F)**.
- Do not use if the hose is kinked, abraded, cut, bulged, or leaking. Do not attempt to repair the hose.
- Do not carry tool by hoses.
- Refer to a HUCK hydraulic tool manual for hose inspection and maintenance intervals.
- Store hose assemblies in a clean dry area.

Hose Type	Minimum Bend Radius	
<b>126107 Series</b>	2.76 Inches	70 mm
<b>118944 and 124881 Series</b>	2.17 Inches	55 mm
<b>HA and HPH Series</b>	1.97 Inches	50 mm



## Safety Instructions

### GLOSSARY OF TERMS AND SYMBOLS:



-Product complies with requirements set forth by the relevant UK and European directives.



-Read manual prior to using this equipment.



-Eye protection is required while using this equipment.



-Hearing protection is required while using this equipment.

Notes: are reminders of required procedures.

***Bold, Italic type, and underline:*** emphasize a specific instruction.



**WARNINGS: Must be understood to avoid severe personal injury.**



**CAUTIONS: Show conditions that will damage equipment or structure.**

### I. GENERAL SAFETY RULES:

1. A half hour long hands-on training session with qualified personnel is recommended before using Huck equipment.
2. Huck equipment must be maintained in a safe working condition at all times. Tools and hoses should be inspected at the beginning of each shift/day for damage or wear. Any repair should be done by a qualified repairman trained on Huck procedures.
3. For multiple hazards, read and understand the safety instructions before installing, operating, repairing, maintaining, changing accessories on, or working near the assembly power tool. Failure to do so can result in serious bodily injury.
4. Only qualified and trained operators should install, adjust or use the assembly power tool.
5. Do not modify this assembly power tool. This can reduce effectiveness of safety measures and increase operator risk.
6. Do not discard safety instructions; give them to the operator.
7. Do not use assembly power tool if it has been damaged.
8. Tools shall be inspected periodically to verify all ratings and markings required, and listed in the manual, are legibly marked on the tool. The employer/operator shall contact the manufacturer to obtain replacement marking labels when necessary. Refer to assembly drawing and parts list for replacement.
9. Tool is only to be used as stated in this manual. Any other use is prohibited.
10. Read MSDS Specifications before servicing the tool. MSDS specifications are available from the product manufacturer or your Huck representative.
11. Only genuine Huck parts shall be used for replacements or spares. Use of any other parts can result in tooling damage or personal injury.
12. Never remove any safety guards or pintail deflectors.
13. Never install a fastener in free air. Personal injury from fastener ejecting may occur.
14. Where applicable, always clear spent pintail out of nose

assembly before installing the next fastener.

15. Check clearance between trigger and work piece to ensure there is no pinch point when tool is activated. Remote triggers are available for hydraulic tooling if pinch point is unavoidable.
16. Do not abuse tool by dropping or using it as a hammer. Never use hydraulic or air lines as a handle or to bend or pry the tool. Reasonable care of installation tools by operators is an important factor in maintaining tool efficiency, eliminating downtime, and preventing an accident which may cause severe personal injury.
17. Never place hands between nose assembly and work piece. Keep hands clear from front of tool.
18. Tools with ejector rods should never be cycled with out nose assembly installed.
19. When two piece lock bolts are being used always make sure the collar orientation is correct. See fastener data sheet for correct positioning.

### II. PROJECTILE HAZARDS:

1. Risk of whipping compressed air hose if tool is pneudraulic or pneumatic.
2. Disconnect the assembly power tool from energy source when changing inserted tools or accessories.
3. Be aware that failure of the workpiece, accessories, or the inserted tool itself can generate high velocity projectiles.
4. Always wear impact resistant eye protection during tool operation. The grade of protection required should be assessed for each use.
5. The risk of others should also be assessed at this time.
6. Ensure that the workpiece is securely fixed.
7. Check that the means of protection from ejection of fastener or pintail is in place and operative.
8. There is possibility of forcible ejection of pintails or spent mandrels from front of tool.

### III. OPERATING HAZARDS:

1. Use of tool can expose the operator's hands to hazards including: crushing, impacts, cuts, abrasions and heat. Wear suitable gloves to protect hands.
2. Operators and maintenance personnel shall be physically able to handle the bulk, weight and power of the tool.
3. Hold the tool correctly and be ready to counteract normal or sudden movements with both hands available.
4. Maintain a balanced body position and secure footing.
5. Release trigger or stop start device in case of interruption of energy supply.
6. Use only fluids and lubricants recommended by the manufacturer.
7. Avoid unsuitable postures, as it is likely for these not to allow counteracting of normal or unexpected tool movement.
8. If the assembly power tool is fixed to a suspension device, make sure that fixation is secure.
9. Beware of the risk of crushing or pinching if nose equipment is not fitted.

Continued on next page...



## Safety Instructions (continued)

### IV. REPETITIVE MOTION HAZARDS:

1. When using assembly power tool, the operator can experience discomfort in the hands, arms, shoulders, neck or other parts of the body.
2. When using tool, the operator should adopt a comfortable posture while maintaining a secure footing and avoid awkward or off balanced postures.
3. The operator should change posture during extended tasks to help avoid discomfort and fatigue.
4. If the operator experiences symptoms such as persistent or recurring discomfort, pain, throbbing, aching, tingling, numbness, burning sensations or stiffness, these warnings should not be ignored. The operator should tell the employer and consult a qualified health professional.

### V. ACCESSORIES HAZARDS:

1. Disconnect tool from energy supply before changing inserted tool or accessory.
2. Use only sizes and types of accessories and consumables that are recommended. Do not use other types or sizes of accessories or consumables.

### VI. WORKPLACE HAZARDS:

1. Be aware of slippery surfaces caused by use of the tool and of trip hazards caused by the air line or hydraulic hose.
2. Proceed with caution while in unfamiliar surroundings; there could be hidden hazards such as electricity or other utility lines.
3. The assembly power tool is not intended for use in potentially explosive environments.
4. Tool is not insulated against contact with electrical power.
5. Ensure there are no electrical cables, gas pipes, etc., which can cause a hazard if damaged by use of the tool.

### VII. NOISE HAZARDS:

1. Exposure to high noise levels can cause permanent, disabling hearing loss and other problems such as tinnitus, therefore risk assessment and the implementation of proper controls is essential.
2. Appropriate controls to reduce the risk may include actions such as damping materials to prevent workpiece from 'ringing'.
3. Use hearing protection in accordance with employer's

instructions and as required by occupational health and safety regulations.

4. Operate and maintain tool as recommended in the instruction handbook to prevent an unnecessary increase in the noise level.
5. Select, maintain and replace the consumable / inserted tool as recommended to prevent an unnecessary increase in noise.
6. If the power tool has a silencer, always ensure that it is in place and in good working order when the tool is being operated.

### VIII. VIBRATION HAZARDS:

1. Exposure to vibration can cause disabling damage to the nerves and blood supply to the hands and arms.
2. Wear warm clothing when working in cold conditions and keep hands warm and dry.
3. If numbness, tingling, pain or whitening of the skin in the fingers or hands, stop using the tool, tell your employer and consult a physician.
4. Support the weight of the tool in a stand, tensioner or balancer in order to have a lighter grip on the tool.

### X. HYDRAULIC TOOL SAFETY INSTRUCTIONS:



#### WARNINGS:

**Do not exceed maximum pull or return settings on tool.**

**Be sure all hose connections are tight. All tool hoses must be connected.**

1. Carry out a daily check for damaged or worn hoses or hydraulic connections and replace if necessary.
2. Wipe all couplers clean before connecting. Failure to do so can result in damage to the quick couplers and cause overheating.
3. Ensure that couplings are clean and correctly engaged before operation.
4. Use only clean oil and filling equipment.
5. Power units require a free flow of air for cooling purposes and should therefore be positioned in a well ventilated area free from hazardous fumes.
6. Do not inspect or clean the tool while the hydraulic power source is connected. Accidental engagement of the tool can cause serious injury.
7. Be sure all hose connections are tight.
8. Wipe all couplers clean before connecting. Failure to do so can result in damage to the quick couplers and cause overheating.

#### Where the following trade names are used in this manual, please note:

**DEXRON** is a registered trademark of General Motors Corporation.

**GLYD Ring** is a registered trademark of Trelleborg Sealing Solutions Germany GmbH

**Loctite** is a registered trademark of Henkel Corporation, U.S.A.

**LUBRIPLATE** is a registered trademark of Fiske Brothers Refining Co.

**MERCON** is a registered trademark of Ford Motor Corp.

**MOLYKOTE** is a registered trademark of Dow Corning Corporation

**Never-Seez** is a registered trademark of Bostik, Inc.

**Quintolubric** is a registered trademark of Quaker Chemical Corp.

**Slic-tite** is a registered trademark of LA-CO Industries, Inc.

**Spirolox** is a registered trademark of Smalley Steel Ring Company

**Teflon** is a registered trademark of Chemours Company FC.

**Threadmate** is a registered trademark of Parker Intangibles LLC.

**TRUARC** is a trademark of TRUARC Co. LLC.

**Vibra-Tite** is a registered trademark of ND Industries, Inc. USA.



## Specifications

**POWER SOURCE:**

Huck Powerig® Hydraulic Power Source

**HOSE KITS:**

Use only genuine HUCK Hose Kits rated @ 10,000 psi (689.5 BAR) working pressure.

**MAX OPERATING TEMP:**

125° F (51.7° C)

**MAX FLOW RATE:**

2 gpm (7.6 l/m)

**MAX PULL PRESSURE:**

7,400 psi (510 BAR)

**MAX RETURN PRESSURE:**

- 2624 series: 3,200 psi (221 BAR)
- 2630 series: 2,600 psi (180 BAR)

**PULL CAPACITY:**

- 2624 series: 30,356 lbs @ 6,500 psi (135.03 kN @ 448 BAR)
- 2630 series: 48,614 lbs @ 6,500 psi (216.2 @ 448 BAR)

**STROKE:**

- 2624 series: 1.687 in. (4.28 cm)
- 2630 series: 1.906 in. (4.84 cm)

**WEIGHT:**

- 2624, 2624-15: 17.5 lbs (7.94 kg)
- 2624HS, 2624-PT, 2624PTD: 24.0 lbs (10.9 kg)
- 2630, 2630RR: 22.43 lbs (10.17 kg)

**HYDRAULIC FLUID:**

Hydraulic fluid shall meet DEXRON® III, DEXRON VI, MERCON®, Allison C-4 or equivalent Automatic Transmission Fluid (ATF) specifications. Fire-resistant fluid may be used if it is an ester-based fluid such as Quintolubric® HFD or equivalent. Water-based fluid shall NOT be used as serious damage to equipment will occur.

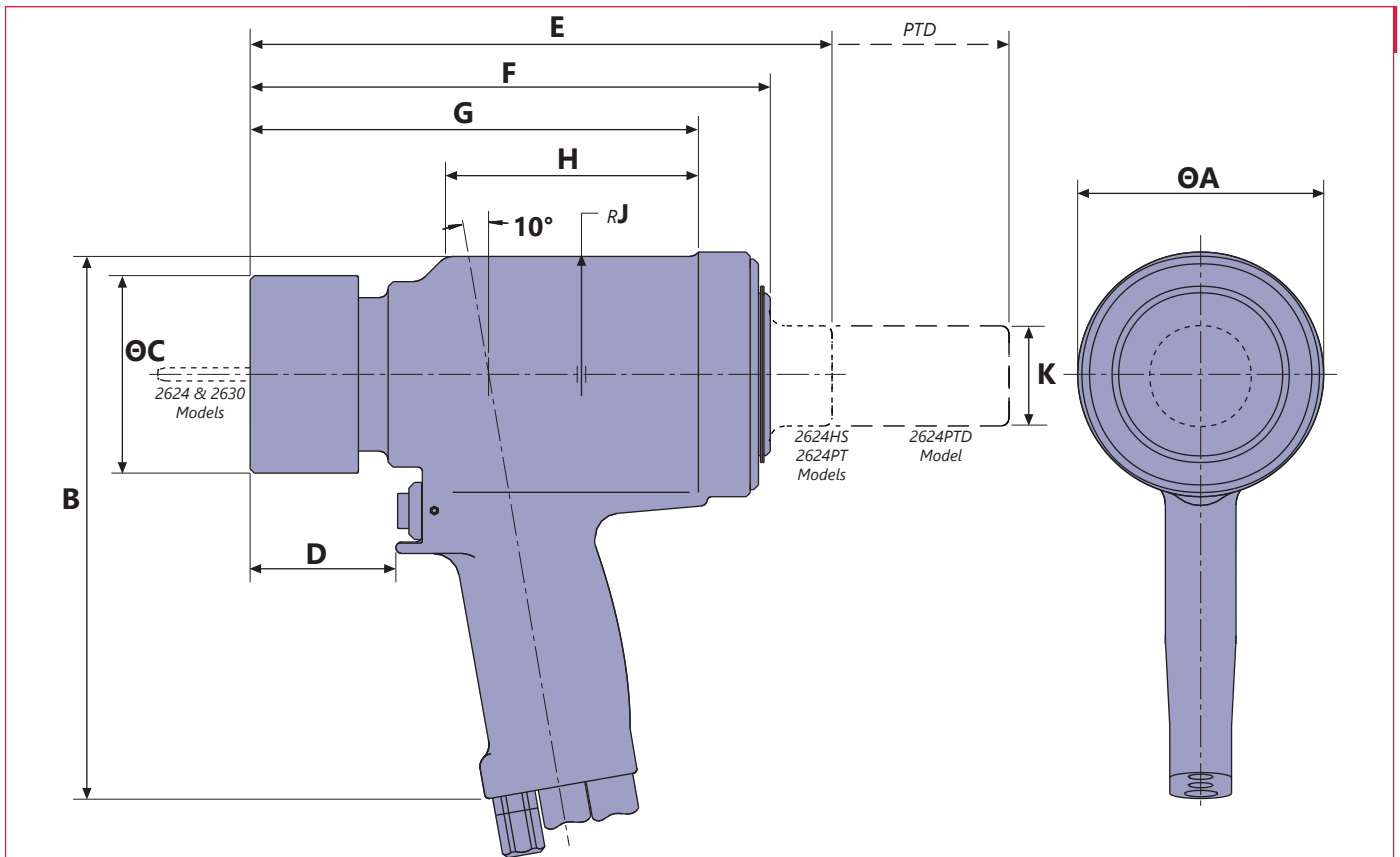

TOOL	A	B	C	D	E	F	G	H	J	K
	inch (cm)	inch (cm)	inch (cm)	inch (cm)	inch (cm)	inch (cm)	inch (cm)	inch (cm)	inch (cm)	inch (cm)
<b>2624</b> <b>2624-15</b>	3.4 (8.8)	7.7 (19.6)	2.8 (7.1)	2.0 (5.2)	n/a	7.3 (18.7)	6.3 (16.1)	3.5 (9.1)	1.7 (4.3)	n/a
<b>2624HS</b> <b>2624-PT</b>	3.4 (8.8)	7.7 (19.6)	2.8 (7.1)	2.0 (5.2)	8.5 (21.6)	7.3 (18.6)	6.3 (16.1)	3.5 (9.1)	1.7 (4.3)	1.2 (3.2)
<b>2624PTD</b>	3.4 (8.8)	7.7 (19.6)	2.8 (7.1)	2.0 (5.2)	11.0 (28.1)	7.3 (18.6)	6.3 (16.1)	3.5 (9.1)	1.7 (4.3)	1.2 (3.2)
<b>2630</b> <b>2630RR</b>	4.9 (12.4)	8.6 (21.9)	3.6 (9.0)	2.2 (5.6)	n/a	7.9 (20.1)	~ 6.4 (17.4)	3.9 (9.9)	2.1 (5.5)	n/a



## Principle of Operation

Upon pressing trigger, a solenoid-operated valve in the Powerig® hydraulic power source directs pressurized fluid through the PULL hose to the front side of the piston; fluid on the RETURN side flows back to the tank (Fig 1a). The piston and nose assembly collet move rearward, installing the fastener. When the piston reaches the end of the PULL stroke, it uncovers flats on the rear end of the dump valve, providing a passage for fluid from the PULL side to the RETURN side of the piston, “dumping” the pressurized fluid back to the tank (Fig 1a).

Upon releasing trigger, the solenoid is de-energized and the valve directs pressurized fluid to the rear of the piston; fluid on the PULL side flows back to the tank (Fig. 1b). The piston and collet move forward, pushing the nose assembly and tool off the installed fastener. When the piston reaches the end of the RETURN stroke, pressure builds, causing the Powerig to shut off, completing the cycle.

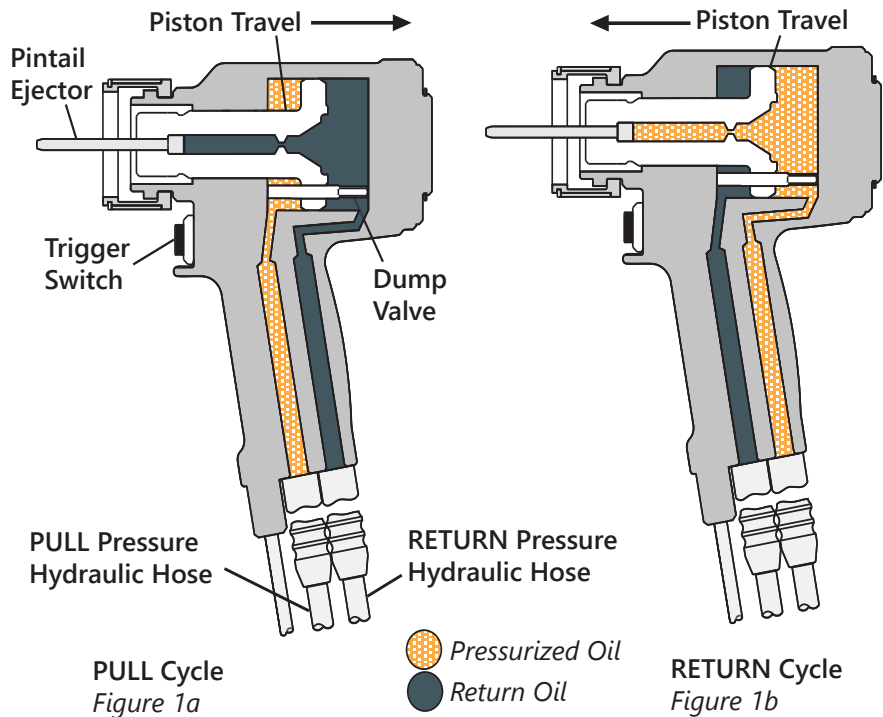

## Preparation for Use



### WARNINGS:

Read entire manual before using tool.

A 30-minute training session with qualified personnel is recommended before using Huck equipment. When operating Huck equipment, always wear approved eye and hearing protection.

Huck Powerig® hydraulic power sources should be used to power Huck tools. Hydraulic power units that deliver high PULL and RETURN pressures, but which are *not equipped with relief valves*, are specifically **NOT RECOMMENDED** and may be dangerous.

Connect tool hydraulic hoses to Powerig *before* connecting tool switch-control cord to Powerig. If not connected in this order and *disconnected in the reverse order*, severe personal injury may occur.

Set PULL and RETURN pressures as specified in SPECIFICATIONS. Failure to properly set these pressures may result in serious personal injury.

Huck Pressure Gauge T-124833CE is available and should be used as indicated in its instruction manual. Ensure there is adequate clearance for the operator's hands before proceeding.



### CAUTION: Keep disconnected hoses and couplers and hydraulic fluid free of foreign matter.

Contaminated fluid can cause valve failures. Apply Parker Threadmate, Loctite 567, or Slic-tite stick to male pipe threads per manufacturer's instructions.

### POWER SOURCE CONNECTIONS

Use a Huck Powerig® hydraulic power source, or equivalent, that has been suitably prepared for operation.

1. Turn OFF the Powerig and disconnect its power supply.
2. Coat the tool's hose-fitting threads with Loctite® 243™ or equivalent, and then connect the hoses to the Powerig.
3. Connect the tool's control switch cord to the Powerig.
4. Connect the Powerig to the power supply and turn it ON. Press and hold the tool trigger for 30 seconds; then press trigger a few times to cycle the tool and circulate the hydraulic fluid. Observe the action of the tool and

check for leaks. Turn OFF the Powerig.

5. Disconnect tool's control switch cord from the Powerig; disconnect the Powerig from the power supply. Select a nose assembly for the fastener to be installed and attach it to the tool.
6. Reconnect the Powerig to the power supply and the tool's switch control cord to the Powerig.
7. Check the operation of nose assembly; install fasteners in a test plate of correct thickness with proper size holes. Inspect installed fasteners.

**NOTE: If fasteners do not pass inspection, see TROUBLESHOOTING to investigate possible causes.**



# Maintenance

Stickers on the tool must be replaced when the cylinder is replaced, or if they become worn, damaged, or unreadable. Refer to **STICKER LOCATIONS** in this manual for information on sticker locations and part numbers.

**CAUTIONS:**  
**Consult the Material Safety Data Sheet (MSDS) before servicing tool.**

**Keep foreign matter out of the hydraulic system. Keep separated parts away from dirty work surfaces.**

**Dirt and debris in hydraulic fluid causes valve failures in tool and Powerig® hydraulic power source.**

**Check components drawings in this manual for correct orientation of polyseals and dump valve.**

**Do not use Teflon® tape on pipe threads. Tape can shred, resulting in malfunctions. Apply Parker Threadmate, Loctite 567, or Slic-tite stick to male pipe threads per manufacturer's instructions.**

**Always replace seals, wipers, and Back-up rings when the tool is disassembled for any reason.**

## POWERIG® HYDRAULIC POWER SOURCE

Maintenance instructions and repair procedures are in the appropriate Powerig hydraulic power source Instruction Manual.

## SYSTEM INSPECTION

An effective maintenance program includes scheduled inspections of the system to detect minor troubles that can be quickly and easily corrected. Huck recommends that you:

Inspect the tool and nose for external damage.

Verify that hoses, fittings, couplings, and electrical connections are secure and free of leaks.

Inspect hydraulic hoses for signs of damage. Replace if necessary.

Inspect the tool, hoses, and Powerig during operation to detect abnormal heating, leaks, or vibration.

## TOOL

At regular intervals, depending on use, replace all O-rings and Back-up rings in the tool. Spare Parts Kits should be kept on hand. Inspect cylinder bore, piston, piston rod, and unloading valve for scored surfaces, excessive wear, and damage; replace as necessary.

## NOSE ASSEMBLY

Daily cleaning of the nose assembly is recommended. This can usually be accomplished by dipping the nose assembly in mineral spirits, or other suitable solvent, to clean the jaws and wash away metal chips and dirt. If a more thorough cleaning or maintenance is necessary, disassemble the nose assembly. Use a sharp pointed "pick" to remove embedded particles from the pull grooves of the jaws.

See **SPECIFICATIONS** for fluid type. Dispose of fluid in accordance with local environmental regulations. Recycle steel, aluminum, and plastic parts in accordance with local lawful and safe practices.

## PREVENTIVE MAINTENANCE

The operating efficiency of your tool is directly related to performance of the entire system. Therefore, a regular schedule of "preventive" maintenance of the tool, nose assembly, hydraulic hoses, trigger and control cord, and Powerig® hydraulic power source will ensure your tool's proper operation and extend its life. Also see **TROUBLESHOOTING**, parts lists, and **DISASSEMBLY** and **ASSEMBLY** procedures in this manual.

## Hydraulic Couplings



## Assembly of NPTF Threaded Components

### AIR FITTINGS

- 1) Apply TEFLON® stick to male threads which do not have pre-applied sealant per manufacturer's recommendations. (Proceed to All Fittings step 2)

### HYDRAULIC FITTINGS

- 1) Apply Threadmate™ to male and female threads which do not have pre-applied sealant per manufacturer's recommendations. (Proceed to All Fittings step 2)

### ALL FITTINGS:

- 2) Tighten to finger-tight condition.
- 3) Wrench tighten to 2-3 turns past finger-tight condition.
- 4) Final thread engagement can be checked (optional) by measuring the dimension from the flange of male fitting to the end of the thread before assembly and subtracting the distance under the flange after assembly.

Thread Size	Final thread engagement at full make-up
1/8-27 NPTF	.235 inch (.59 cm)
1/4-18 NPTF	.339 inch (.86 cm)
3/8-18 NPTF	.351 inch (.89 cm)





## Disassembly

This procedure is for complete disassembly of the tool. Disassemble *only* those components necessary to replace damaged rings and worn or damaged components. Always use a soft-jaw vise to avoid damaging the tool.



**WARNING: Disconnect the tool control cord from the Powerig hydraulic power source before disconnecting the hydraulic hoses from it.**

**If not disconnected in this order, serious personal injury may occur.**



**CAUTION: Do not re-use seals, wipers, or rings; irreparable tool damage could occur. Discard these parts and use replacements (see SPARE PARTS SERVICE KITS).**

1. Disconnect electrical or air connector from Powerig® hydraulic power source. Uncouple tool hydraulic hoses.
2. Remove nose assembly.
3. Unscrew coupling nipple and coupling body. Drain hydraulic hoses into container. Discard fluid.
4. Push rearward on Piston until remaining hydraulic fluid is drained into container. Discard fluid.

**NOTE: Do not remove hydraulic hoses from the tool unless replacing the hoses. If it is necessary to remove hoses, uncover the hose fittings by sliding back the plastic shrouds.**

5. **Use these steps only if the switch, wire, or electrical connector needs repair.** Remove retaining nut and locking ferrule from strain relief. Loosen setscrew. Remove trigger switch. Loosen and remove the two wires from the switch. Remove cord from tool. Disassemble electrical connector (P/N **110686**).
6. Models **2624, 2624-15**: Remove end cap retaining ring, cover plate, and locking disk. (Figure 8)  
Models **2624HS, 2624-PT, 2624PTD**: Remove screws, retainer, deflector (2624PTD), and locking disk. (Figures 9 & 10)  
Models **2630, 2630RR**: Remove retaining ring from rear of tool; then remove clamshell retainer assembly and locking disk. (Figure 11)
7. Insert hex key (P/N **126981**, shipped with tool) into end cap. (Figure 2) Using a wrench, unscrew the end cap from the cylinder.
8. Models **2624, 2624-15, 2630, 2630RR**: Remove the O-ring and Back-up ring from end cap.  
Models **2624HS, 2624-PTD**: Remove the O-ring and Back-up ring from front gland, and retaining ring, washer, polyseal, and wiper seal from end cap.
9. Remove the dump valve from rear of cylinder.
10. Slide spacer over piston and thread Piston Assembly Tool onto front of piston. Using a press, push front gland and piston assemblies out the rear of the cylinder. (Figure 3)

11. Remove Piston Assembly Tool and spacer.
12. Slide front gland off of piston. Remove wiper, wiper housing, Back-up ring, O-ring, and Polyseal from front gland.
13. Remove the GLYD ring from the piston. (Figure 5)
14. Models **2624, 2624-15, 2630, 2630RR**: Hold piston in a vise and remove ejector gland/cartridge assembly with hex key (P/N 122048). (Figure 4)
15. Models **2624, 2624-15, 2630, 2630RR**: Remove ejector rod, wiper, and all seals from gland/cartridge.

The tool has been properly disassembled. Store all re-usable parts (screws and disassembled components) in a clean, dry area.

Figure 2

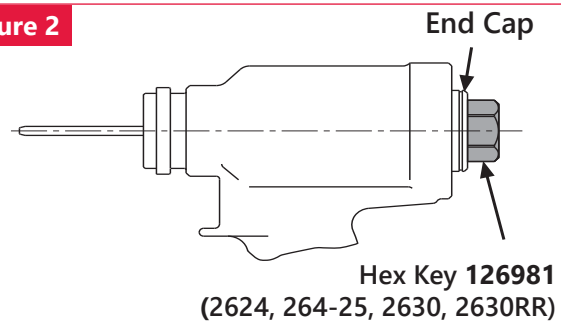

Figure 3

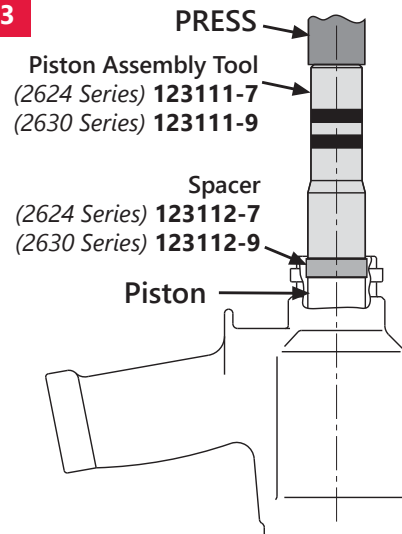
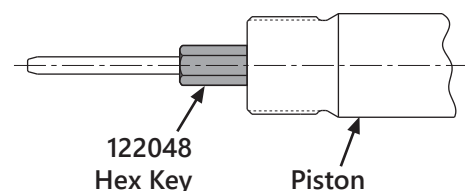

Figure 4





## Assembly

NOTE: When reassembling the tool, always replace damaged and defective parts, and all seals, wipers, O-rings, and Back-up rings of subassemblies. Prior to reassembling the tool, HUCK recommends having the following items accessible.

- The appropriate Huck Spare Parts Service Kit: P/N 2624KIT (2624, 2624-15), P/N 2624HSKIT (2624HS, 2624-PT, 2624PTD), or P/N 2630KIT (2630, 2630RR)
- LUBRIPLATE® 130-AA (available as P/N 502723) or SUPER-O-Lube® (available as P/N 505476)



**WARNING: Do not omit any seals during servicing; leaks will result and serious personal injury can occur.**



**CAUTION: Do not use TEFLON® tape on pipe threads. Tape can shred, resulting in malfunctions. Apply Parker Threadmate, Loctite 567, or Slic-tite stick to male pipe threads per manufacturer's instructions.**

### BEFORE ASSEMBLING THE TOOL:

- Clean components in mineral spirits or other solvent compatible with O-ring seals.
  - Clean out O-ring grooves.
  - Inspect components for scoring, excessive wear, and damage; replace as necessary.
  - Replace O-rings and Back-up rings. See Assembly Drawings for guidance on positioning these rings.
- When assembling the tool, take care not to damage O-rings, Quad-rings, Back-up rings.
- Smear LUBRIPLATE® 130-AA or SUPER-O-LUBE® on rings and mating parts to ease assembly.

### TO ASSEMBLE THE TOOL:

1. **Models 2624, 2624-15, 2630, 2630RR:** Assemble all seals, washers, wipers, rings, and ejector rod into ejector gland/cartridge. Hold the piston in a vise with soft jaws and install assembled ejector gland/cartridge assembly. Use hex key (P/N 122048) to tighten.
2. Thread the Piston Assembly Tool and GLYD ring onto the piston (Figure 5). **NOTE: Do not install the spacer. The spacer is only used during disassembly procedure, as it assists in pushing out the front gland assembly along with the piston.**
3. Install Polyseal, O-ring, Back-up ring, wiper housing, and wiper into front gland. (Figure 5)
4. Lubricate the piston assembly tool and the piston; then slide the assembled gland over the piston assembly tool onto the piston. (Figure 5)
5. Thread the piston insertion tool into the back of the cylinder. (Figure 6)
6. Using a press, push the piston and front gland assembly into the back of the cylinder. (Figure 6)
7. Remove the piston assembly tool from the front of the cylinder, and the piston insertion tool from the rear of it.
8. At the rear of the cylinder, install the dump valve (Figure 8) with the four flats facing the rear of the tool.
9. Install O-ring and Back-up ring on the end cap. **Models 2624HS, 2624-PT, 2624PTD:** Install Back-up ring, O-ring, wiper seal, Polyseal, washer, and retaining ring into the end cap. (Figure 7)
10. Insert the hex key into the end cap. Use a wrench to thread the end cap into the back of the cylinder and

tighten. (Figure 2)

11. **Models 2624, 2624-15:** Install locking disk, cover plate, and retaining ring. (Figure 8)
  - Models 2624HS, 2624-PT, 2624PTD:** Install locking disk, retainer, and screws. (Fig. 9); 2624PTD see Fig. 10
  - Models 2630, 2630RR:** Install locking disk, clamshell retainer assembly, and retaining ring. (Figure 11)
- If removed during disassembly, reinstall the electrical connector. **If the switch or wire was removed, replace as follows:** Slide the retaining nut and ferrule onto the electrical wire. Feed the wire through the handle and pull out through the trigger switch hole. Attach the wires to trigger switch and push assembly back into the handle. Tighten the setscrew to hold trigger switch in place. Slide ferrule into the strain relief housing, then thread and tighten the retaining nut.
  - If removed during disassembly, re-install hydraulic hoses in handle ports marked "P" and "R".
  - Install male coupler 110438 on PULL pressure side and female coupler 110439 on RETURN pressure side of hoses.

Figure 5

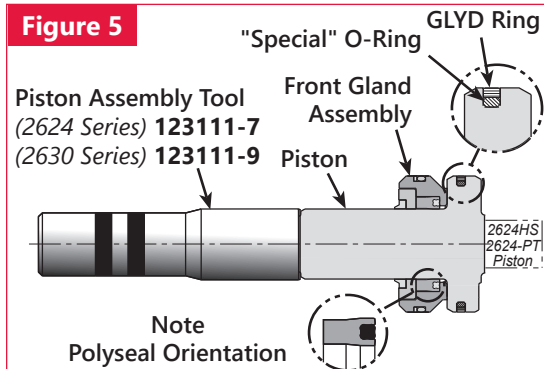

Figure 6

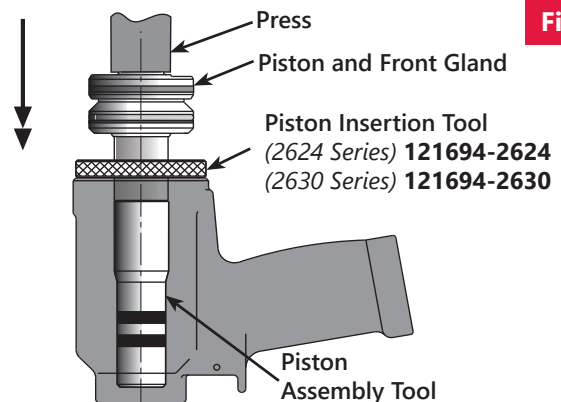
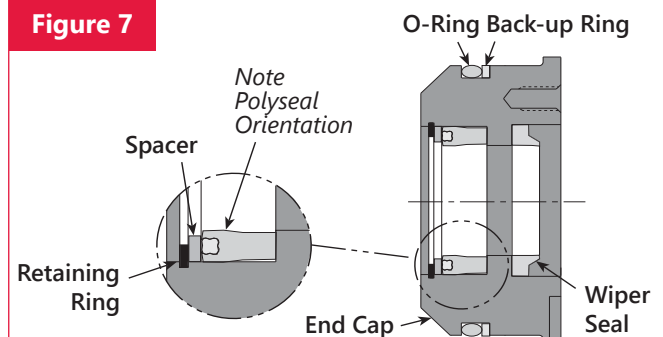

Figure 7





# Assembly Drawing 2624 & 2624-15

**Figure 8**

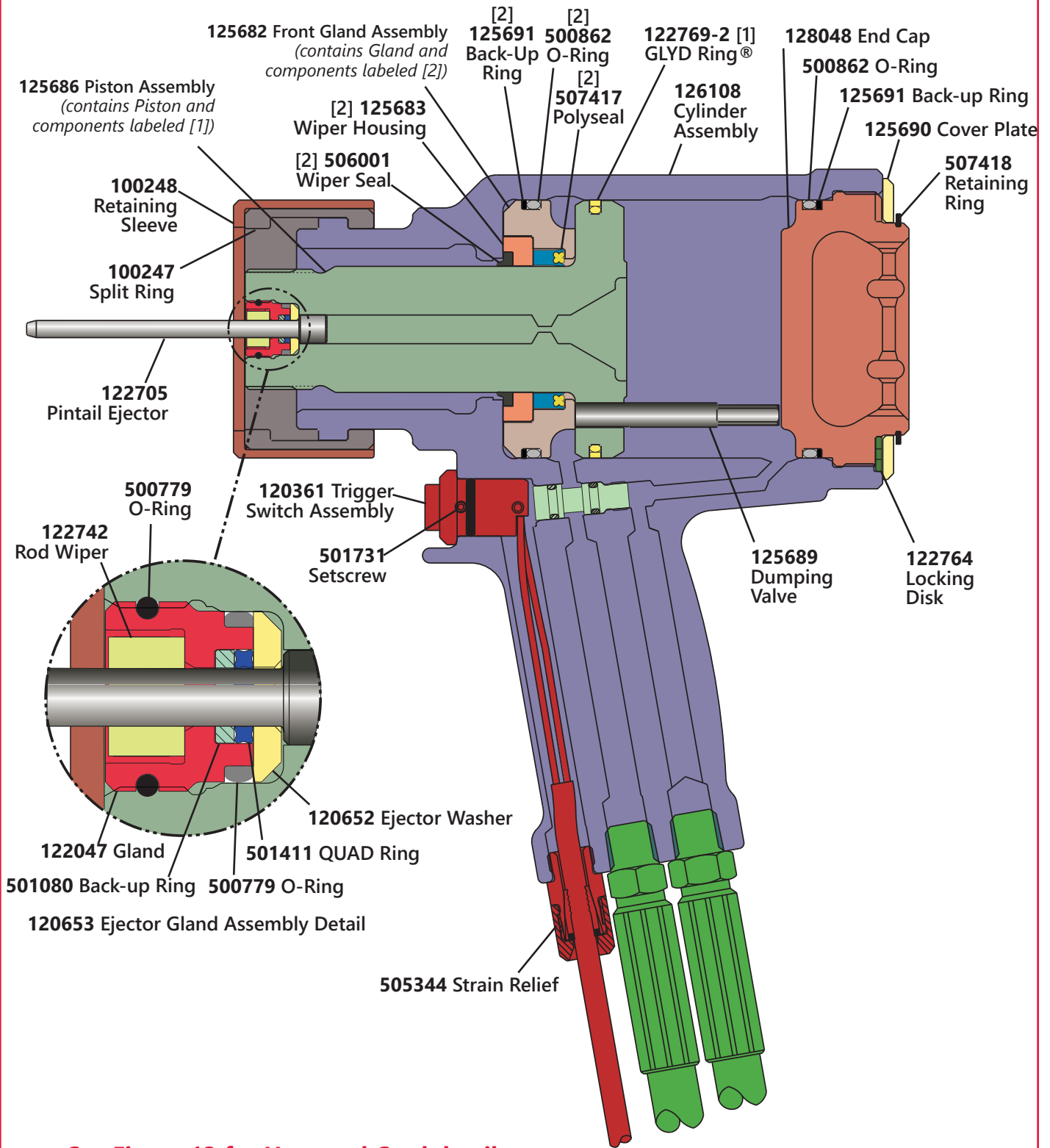

**See Figure 13 for Hose and Cord details.**



# Assembly Drawing 2624HS & 2624-PT

Figure 9

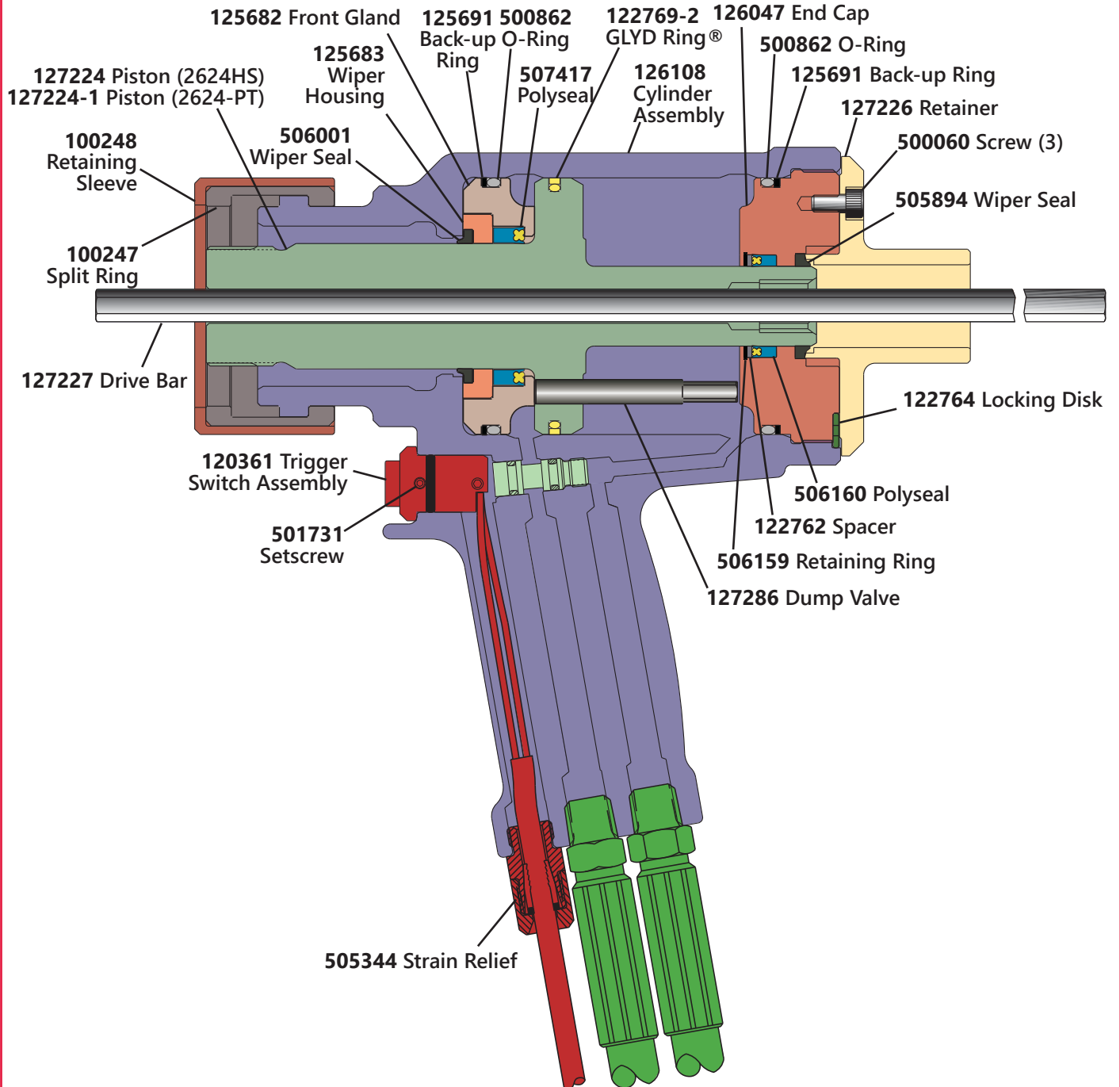

See Figure 13 for Hose and Cord details.



# Assembly Drawing 2624PTD

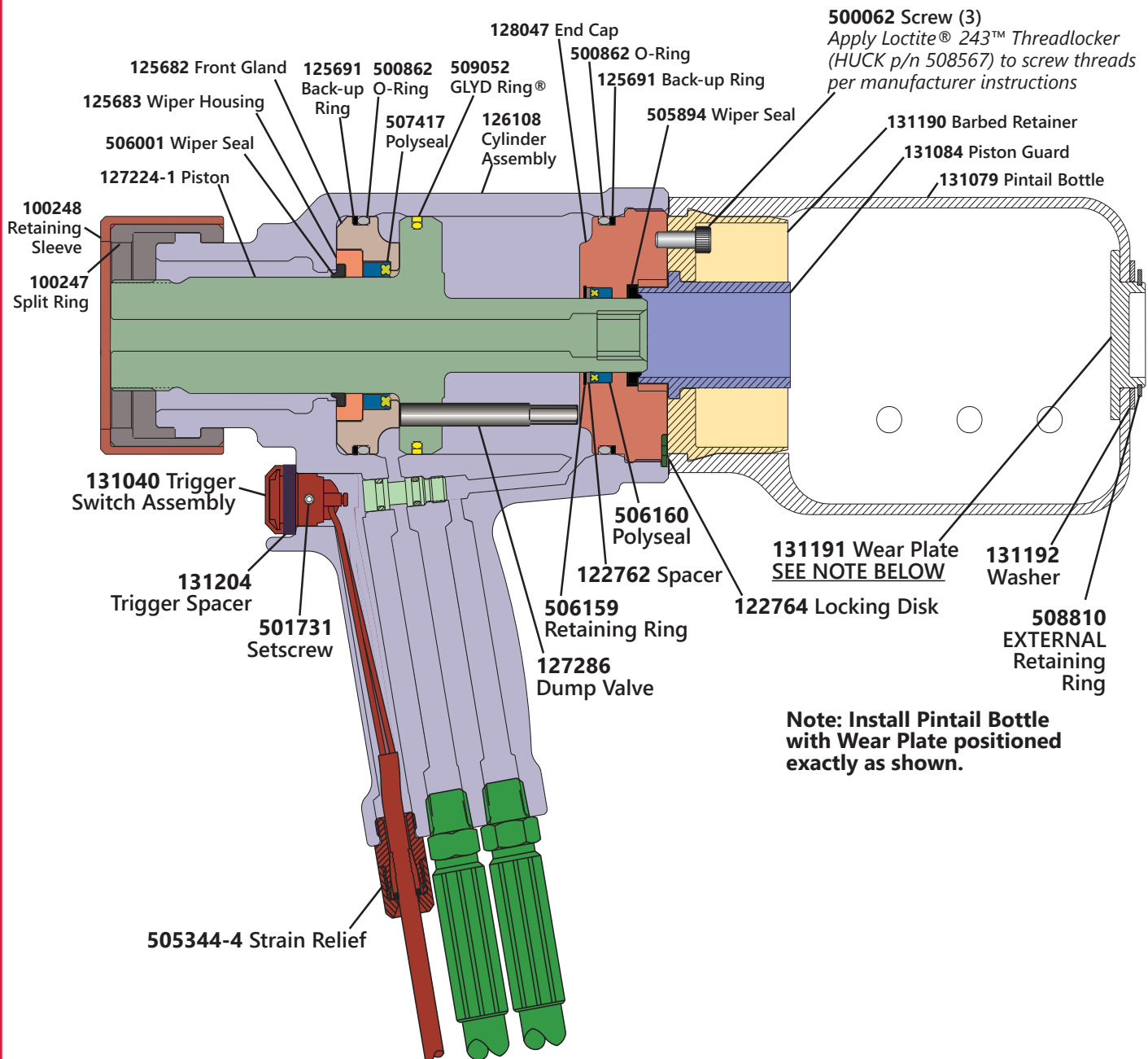

## 2624PTD ASSEMBLY INSTRUCTIONS CONTINUED FROM PAGE 11, INSTRUCTION 11:

After installing End Cap and Wiper Seal, assemble Wear Plate inside Pintail Bottle exactly as shown, with Washer and Retaining Ring outside Bottle.

Place Piston Guard into Barbed Retainer, and seat both over rear of Piston, as shown. Secure Retainer and Guard in place with 3 Screws.

Press Pintail Bottle over Barbed Retainer until it seats on back of tool cylinder.

2624PTD\_revH

**See Figure 13 for Hose and Cord details.**

**Figure 10**



# Assembly Drawing 2630 & 2630RR

Figure 11

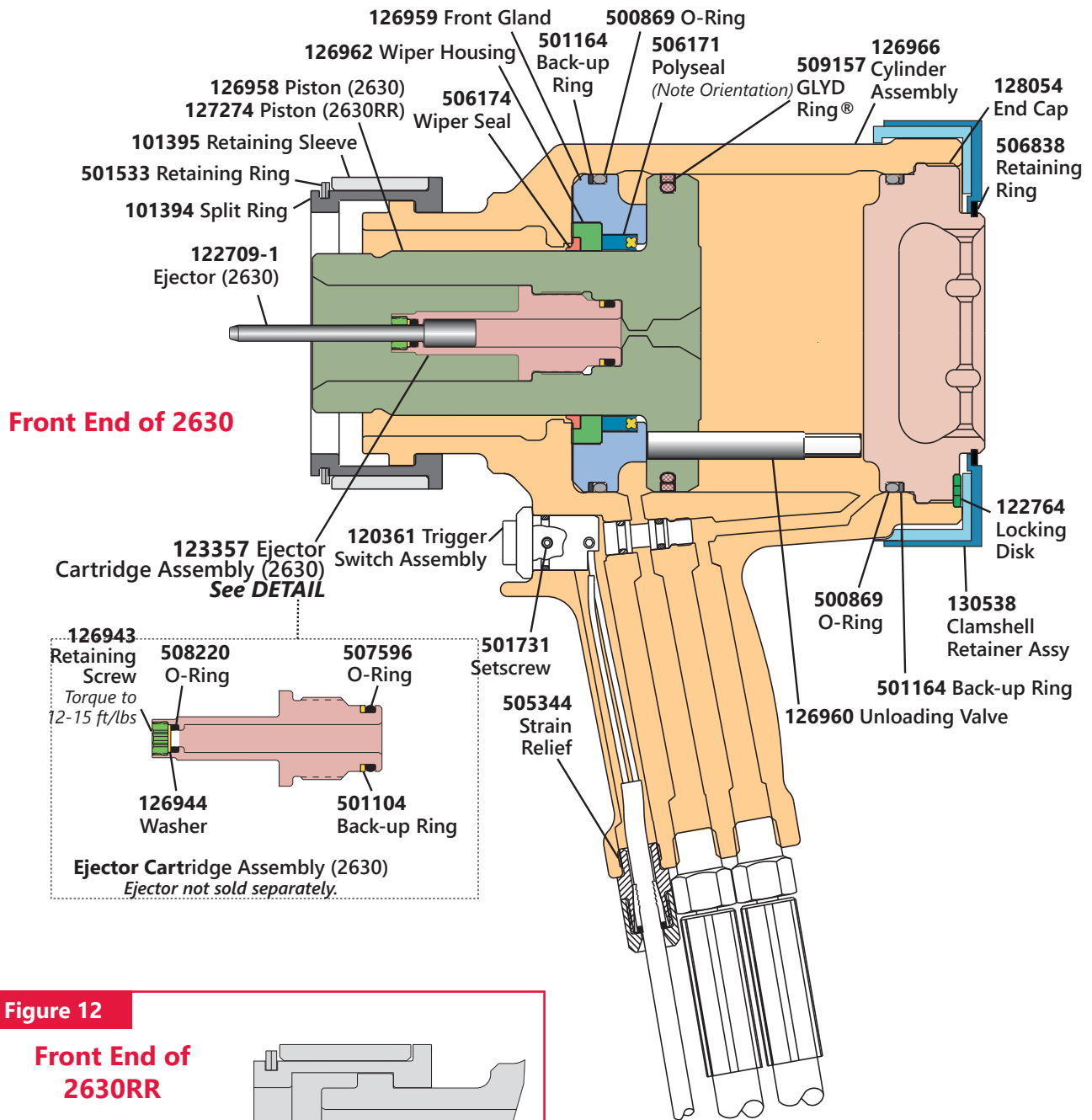
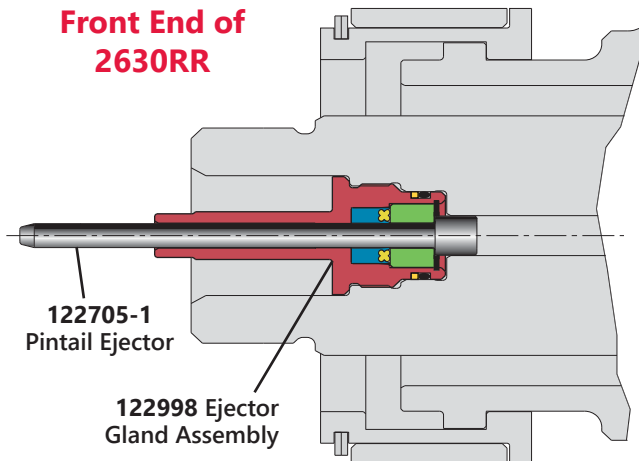

Figure 12

## Front End of 2630RR



See Figure 13 for Hose and Cord details.

2630\_revK  
 2630RR\_revB



# Hose Assembly

Figure 13

Tool Model	Hose Assembly	Control Cord
2624, 2630, 2630RR	126107-1 (2 ft.)	123337-1
2624-15, 2624HS, 2624-PT	126107-2 (16 ft.)	123336
2624PTD	HPHY02-BC01 (2 ft.)	131043

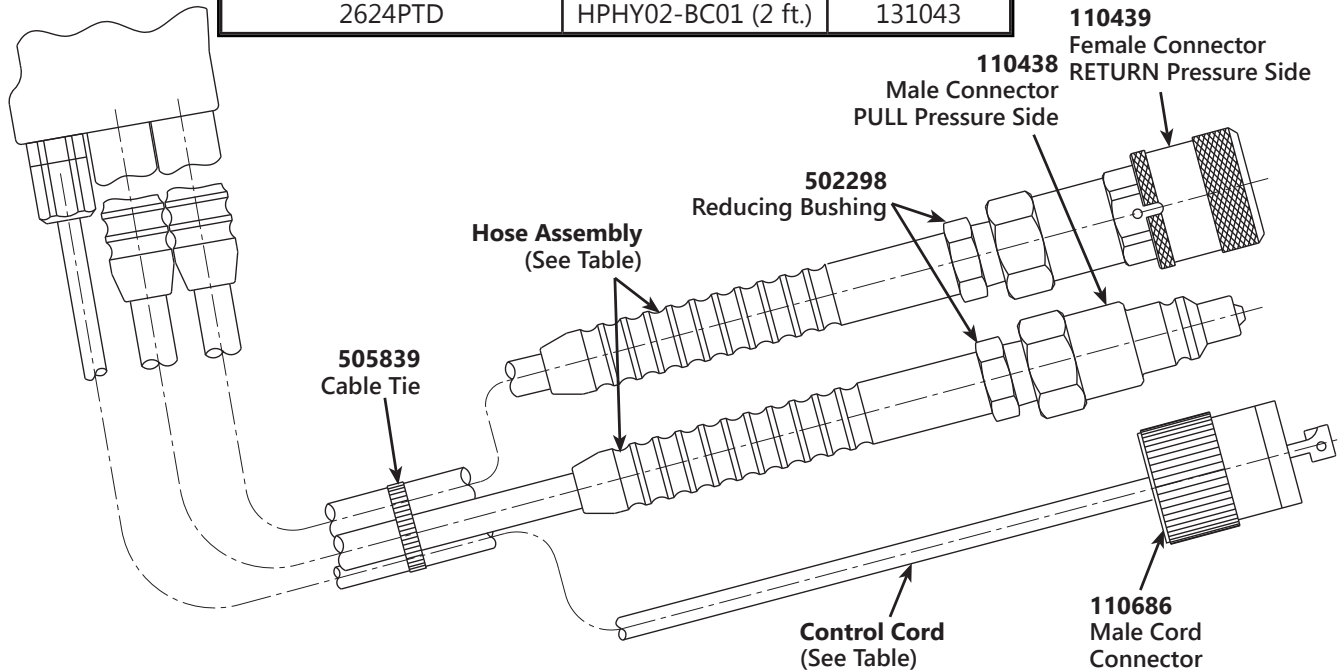

## Kits & Accessories

### SERVICE KITS

- 2624, 2624-15 - 2624KIT
- 2624HS, 2624-PT - 2624HSKIT
- 2630, 2630RR - 2630KIT

### ASSEMBLY TOOL KITS

- 2624 / 2624HS Assembly Tool Kit-** 123110-9
- Includes: (Fig. 3 & 6)*
- Spacer - 123112-7
- Piston Assembly Tool - 123111-7
- Piston Insertion Tool - 121694-2624
- 2630 Assembly Tool Kit** - 123110-13
- Includes: (Fig. 3 & 6)*
- Spacer - 123112-9
- Piston Assembly Tool - 123111-9
- Piston Insertion Tool - 121694-2630

### ACCESSORIES

- Ejector Gland Hex Key** - 122048
- 2624, 2624-15
- End Cap Hex Key** - 126981
- Remote Trigger (All Models)** - 123381-24

### Suspension Brackets

*Now available are Suspension Brackets which enable a user to install fasteners with increased ergonomic flexibility. Each Suspension Bracket Assembly contains the Bracket and Hardware shown below.*

- 2624 series - 127400-2624
- 2630 series - 127400-2630

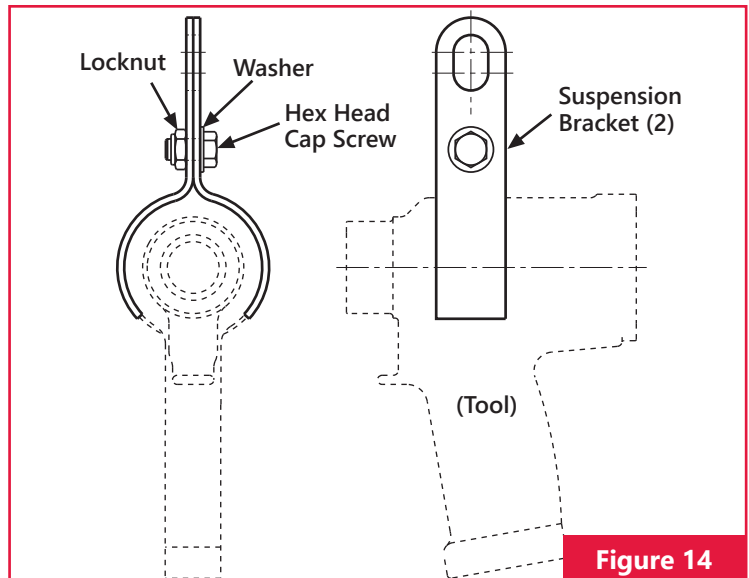

Figure 14



## Sticker Locations

The 2600 Series tools are labeled with important stickers that contain safety and pressure-settings information. These stickers must remain on the tools and be legible. Damaged, worn, and missing stickers must be replaced. Sticker part numbers are shown below.

**Figure 15**

The following stickers must be on the main Cylinder of the tool.

**590512-5 CE & WARNING**  
Sticker (*Maximum Operating Pressures*)

**590517 HUCK &**  
Year of Mfr Sticker

**590550 Pintail Bottle Sticker (2624PTD Only)**

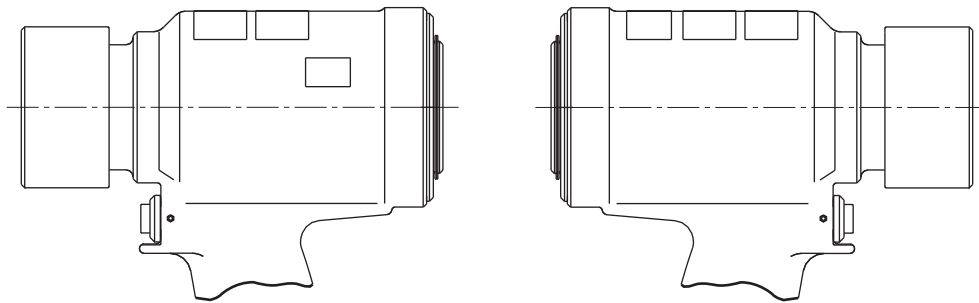

590517



590550  
**2624PTD ONLY**



590512-5





## Troubleshooting

Always check the simplest possible cause (such as a loose or disconnected trigger line) of a malfunction first. Then proceed logically, eliminating other possible causes until the cause is discovered. Where possible, substitute known good parts for suspected defective parts. Use this Troubleshooting information to aid in locating and correcting trouble.

- 1. Tool fails to operate when trigger is depressed.**
  - a. Inoperative Powerig® hydraulic power source. See applicable instruction manual.
  - b. Loose air or electric connections.
  - c. Damaged trigger assembly.
  - d. Loose or faulty hydraulic hose couplings.
  - e. Unloading valve not installed in tool.
- 2. Tool operates in reverse.**
  - a. Reversed hydraulic hose connections between hydraulic unit and tool.
- 3. Tool leaks hydraulic fluid.**
  - a. Defective tool O-rings or loose hose connections at tool.
- 4. Hydraulic couplers leak fluid.**
  - a. Damaged or worn O-rings in coupler body. See Coupler 110440.
- 5. Hydraulic fluid overheats.**
  - a. Hydraulic unit not operating properly.
  - b. Unloading valve installed incorrectly.
  - c. Powerig hydraulic power source running in reverse (918: 918-5) See unit's manual.
- 6. Tool operates erratically and fails to install fastener properly.**
  - a. Low or erratic hydraulic pressure; air in system.
  - b. Damaged or worn piston O-ring in tool.
  - c. Unloading valve installed incorrectly.
  - d. Excessive wear on sliding surfaces of tool parts.
  - e. Excessive wear of unloading valve in tool.
- 7. Pull grooves on fastener pintail stripped during PULL stroke.**
  - a. Operator not sliding anvil completely onto fastener pintail.
  - b. Incorrect fastener grip.
  - c. Worn or damaged jaw segments.
  - d. Metal particles in jaw segments pull grooves.
  - e. Excessive sheet gap.
- 8. Collar of HUCKBOLT® fastener not completely swaged.**
  - a. Improper tool operation. See Trouble 6.
  - b. Scored anvil.
- 9. Shear collar on Huck blind fastener not driven.**
  - a. Improper tool operation.
  - b. Worn or damaged driving anvil in nose assembly.
- 10. Tool "hangs-up" on swaged collar of HUCKBOLT Fastener.**
  - a. Improper tool operation. See Trouble 6.
  - b. RETURN pressure too low.
  - c. Nose assembly not installed correctly.
- 11. Pintail of fastener fails to break.**
  - a. Improper tool operation. See Trouble 6.
  - b. Pull grooves on fastener are stripped. See Trouble 7.
  - c. PULL pressure too low.
  - d. Worn unloading valve.



# Notes



## Limited Warranties

### Limited Lifetime Warranty on BobTail® Tools:

Huck International, Inc. warrants to the original purchaser that its BobTail® installation tools manufactured after 12/1/2016 shall be free from defects in materials and workmanship for its **useful lifetime**. This warranty does not cover special order / non-standard products, or part failure due to normal wear, tool abuse or misapplication, or user non-compliance with the service requirements and conditions detailed in the product literature.

### Two Year Limited Warranty on Installation Tools:

Huck International, Inc. warrants that its installation tools and Powerig® hydraulic power sources manufactured after 12/1/2016 shall be free from defects in materials and workmanship for a period of two years from date of purchase by the end user. This warranty does not cover special order / non-standard products, or part failure due to normal wear, tool abuse or misapplication, or user non-compliance with the service requirements and conditions detailed in the product literature.

### 90 Day Limited Warranty on Nose Assemblies and Accessories:

Huck International, Inc. warrants that its nose assemblies and accessories shall be free from defects in materials and workmanship for a period of 90 days from date of purchase by the end user. This warranty does not cover special clearance noses, or special order / non-standard product, or part failure due to normal wear, abuse or misapplication, or user non-compliance with the service requirements and conditions detailed in the product literature.

**Useful lifetime** is defined as the period over which the product is expected to last physically, up to the point when replacement is required due to either normal in-service wear, or as part of a complete overhaul. Determination is made on a case-by case basis upon return of parts to Huck International, Inc. for evaluation.

### Tooling, Part(s) and Other Items not manufactured by Huck:

HUCK makes no warranty with respect to the tooling, part(s), or other items manufactured by third parties. HUCK expressly disclaims any warranty expressed or implied, as to the condition, design, operation, merchantability, or fitness for use of any tool, part(s), or other items thereof not manufactured by HUCK. HUCK shall not be liable for any loss or damage, directly or indirectly, arising from the use of such tooling, part(s), or other items or breach of warranty or for any claim for incidental or consequential damages.

Huck shall not be liable for any loss or damage resulting from delays or non-fulfillment of orders owing to strikes, fires, accidents, transportation companies or for any reason or reasons beyond the control of the Huck or its suppliers.

### Huck Installation Equipment:

Huck International, Inc. reserves the right to make changes in specifications and design and to discontinue models without notice.

Huck Installation Equipment should be serviced by trained service technicians only.

Always give the serial number of the equipment when corresponding or ordering service parts.

Complete repair facilities are maintained by Huck International, Inc. Please contact one of the offices listed below.

#### Eastern

One Corporate Drive Kingston, New York 12401-0250  
Telephone (845) 331-7300 FAX (845) 334-7333

#### Outside USA and Canada

Contact your nearest Huck International location (see reverse).

In addition to the above repair facilities, there are Authorized Tool Service Centers (ATSC's) located throughout the United States. These service centers offer repair services, spare parts, Service Parts Kits, Service Tool Kits and Nose Assemblies. Please contact your Huck Representative or the nearest Huck International location (see reverse) for the ATSC in your area.



Howmet Inc. (NYSE: HWM) creates breakthrough products that shape industries. Working in close partnership with our customers, we solve complex engineering challenges to transform the way we fly, drive, build and power.

Through the ingenuity of our people and cutting-edge advanced manufacturing, we deliver these products at a quality and efficiency that ensures customer success and shareholder value.

## Howmet Fastening Systems Tooling Support Locations

### INDUSTRIAL NORTH AMERICA

#### Kingston Operations

1 Corporate Drive  
Kingston, NY 12401  
Tel: +1-800-278-4825  
Fax: +1-845-334-7333  
hfs.sales.kingston@Howmet.com

#### Tracy Operations

1925 North MacArthur Drive  
Tracy, CA 95376  
Tel: +1-800-826-2884  
Fax: +1-800-573-2645  
hfs.sales.idg@Howmet.com

#### Waco Operations

PO Box 8117  
8001 Imperial Drive  
Waco, TX 76714-8117  
Tel: +1-800-388-4825  
Fax: +1-800-798-4825  
huck.waco@Howmet.com

### INDUSTRIAL GLOBAL

#### Tokyo Operations (Japan and Korea)

1013 Hibiya U-1 Bldg.  
Uchisaiwai-cho 1-1-7  
Chiyoda-ku, Tokyo  
100-0011 Japan  
Tel: +81-3-3539-6594  
Fax: +81-3-3539-6585

#### Melbourne Operations

1508 Centre Road  
Clayton, Victoria  
Australia 3168  
Tel: +613-8545-3333  
Fax: +613-8545-3390  
hfsmel.sales@Howmet.com

#### Suzhou Operations

58 Yinsheng Road,  
SIP Suzhou, Jiangsu  
215126 China  
Tel: +86-512-62863800-8888

#### Telford Operations

Unit C, Stafford Park 7  
Telford, Shropshire  
England TF3 3BQ  
Tel: +44-(0)-1952-290011  
Fax: +44-(0)-1952-207701  
THIsales@howmet.com

### AEROSPACE NORTH AMERICA

#### Kingston Operations

1 Corporate Drive  
Kingston, NY 12401  
Tel: +1-800-278-4825  
Fax: +1-845-334-7333  
hfs.sales.kingston@Howmet.com

#### Simi Valley Operations

3990A Heritage Oak Court  
Simi Valley, CA 93063  
Tel: +1-805-527-3600  
Fax: +1-805-527-0900  
www.hfs-simivalley.com  
SMV.HFSSales@Howmet.com

### AEROSPACE GLOBAL

#### Aichach Operations

Robert-Bosch Str. 4  
Aichach 86551  
Germany  
Tel: +49-8251-8757-0  
AICSalesDL@Howmet.com

#### Cergy Operations

15 Rue du Petit Albi  
F-95611 Cergy Pontoise  
France  
Tel: +33-1-34-33-98-00  
Fax: +33-1-34-33-97-77

#### Hong Kong Operations

88 Hing Fat Street, 27th Floor  
Causeway Bay  
Hong Kong, China  
Tel: +852-2864-2012  
HKSSalesDL@howmet.com



© 2021 Howmet Aerospace, Inc.  
**Howmet Fastening Systems**  
**Kingston Operations**  
1 Corporate Drive, Kingston, NY 12401  
Tel: 800-431-3091 • Fax: 845-334-7333  
[www.hfsindustrial.com/us](http://www.hfsindustrial.com/us)



Huck provides technical assistance regarding the use and application of Huck fasteners and tooling. **NOTICE:** The information contained in this publication is only for general guidance with regard to properties of the products shown and/or the means for selecting such products, and is not intended to create any warranty, express, implied, or statutory; all warranties are contained only in Huck's written quotations, acknowledgments, and/or purchase orders. It is recommended that the user secure specific, up-to-date data and information regarding each application and/or use of such products.