

Engineering Overview & Guidelines:

Fastening Options to Meet
the Design Challenges of
Trailer Manufacturers



By Eur Ing Andy Smith CEng FIMechE BEng (Hons)

Engineering Manager

Howmet Fastening Systems





Contents

1. Introduction	3
2. Installation	4
3. Joint Performance	7
4. Lifetime Cost	9
5. Summary & Conclusions	10
6. About Howmet Fastening Systems	11





Introduction

The optimisation of the design of trailers for efficiency, durability and reliability is of paramount importance. Designers and manufacturers have an evolving and broadening range of engineering options and opportunities to improve their trailer designs from all points-of-view.

The chassis or sub frame of a trailer is perhaps the most important component as it provides the core structure and strength and is subjected to the highest stresses and strains. It must survive these without compromise in performance, or any effect on the structural integrity of the vehicle through many thousands of hours of operation in the most challenging environmental conditions.

Often, the most vulnerable point on a design is where there is an interface or join between components. This holds true in the trailer industry, where the method used to join the main components and structures that combine to make up the sub frame or chassis are critical. It is essential to carefully review all available options for joining the trailer chassis and various options can be

benchmarked against a list of criteria before settling on the best, or best combinations of options.

This paper looks at the current options for joining sub frame or chassis elements and their pros and cons. Some have been on the market for many decades and are well known and used, whereas others are less well known but offer a significant challenge to the incumbent options for trailer designs. One such technology is LockBolts, and recent evolutions in their design by Howmet Fastening Systems under the Huck brand name have resulted in improvements in performance, installation and total cost of ownership.

Further detailed reading and technical information can be found [here](#).

Trailer fastening method design considerations

The considerations associated with trailer chassis and sub frame fastening methods can be partitioned into three main areas:

- 1) Installation speed and ease
- 2) Joint performance
- 3) Lifetime cost

This whitepaper will discuss the above considerations in relation to a) welding, b) nuts and bolts and c) LockBolts.



1. Installation

The installation process - Speed, ease of use and long-term implications

Welding

Welding is an effective and proven joining method which has been used for a long time. However, as environmental, health and safety expectations are becoming more and more relevant, the process has found itself under some scrutiny.

Depending on the skill level and experience of the individual welder, speed, repeatability and quality can all be impacted when using welded joints. Any contaminants on the surfaces of the mating parts can also affect the integrity of the weld, so studious and time-consuming preparation and surface cleaning is vital. Unfortunately, this in-turn may also compromise corrosion resistance in the localised area and post welding treatments, coatings or painting may be necessary in addition to weld inspection. All of this makes for a lengthy and somewhat unpredictable installation process.

Welding is viewed by many as a dirty process. Safety is a critical issue, from the release of fumes to the risk of fires starting from random sparks. At the same time, spent rods and other remnants of the welding process are an ongoing housekeeping issue in workshops where welding is performed on a regular basis.

The sheer scale of the equipment when combined with the setup time and cost makes welding a very inflexible fastening method, being more suited to repetitive processes.

Nuts & bolts

Nuts and bolts are of course familiar to engineers and used in millions of applications around the world, from small intricate assemblies through to major infrastructure installations such as bridges and offshore platforms.

From an assembly point-of-view, access is required from both sides of the parts to be joined; one side needing to be braced, whilst the other is tightened. To ensure a correct installation torque is achieved a torque wrench needs to be applied. Torque wrenches need a level of skill to use correctly and must be periodically calibrated. Even when installed and checked, the installed values of the fastener can vary significantly.

When fastening larger components, nuts and bolts typically require tightening in stages to avoid creep or misalignment of the materials. In practice this means fitting the nuts over the bolts and tightening all along the length of the material to a low torque, then going back over and tightening up to full torque. If nut and bolts at one end are tightened before those at the other end are installed, creep can be a serious issue. This makes what should be a simple installation into a more complex and time-consuming process.

Typically, a physical post-installation inspection is necessary to ensure that all bolts are tightened to specification. In a large, complex trailer chassis assembly there may be hundreds of fasteners so additional checks post-installation can be costly and time consuming. A visual check of a nut and bolt unfortunately does not ensure it is correctly torqued.

Lockbolts

Awareness of LockBolt technology has accelerated in the last 10 years but still lags behind welding and nuts and bolts, despite offering several key advantages over them in applications like trailer chassis.

LockBolts consist of two parts: a pin and a collar but use an entirely different installation method to nuts and bolts. Specially designed ergonomic installation tooling (driven by pneumatic, hydraulic or battery power) is used to swage the collar materials into the grooves of the pin providing a permanent and completely vibration resistant joint.

1. Installation

This simple process typically takes only 2 seconds to complete making it one of the quickest joining methods available.

The following diagram demonstrates the LockBolt installation process:

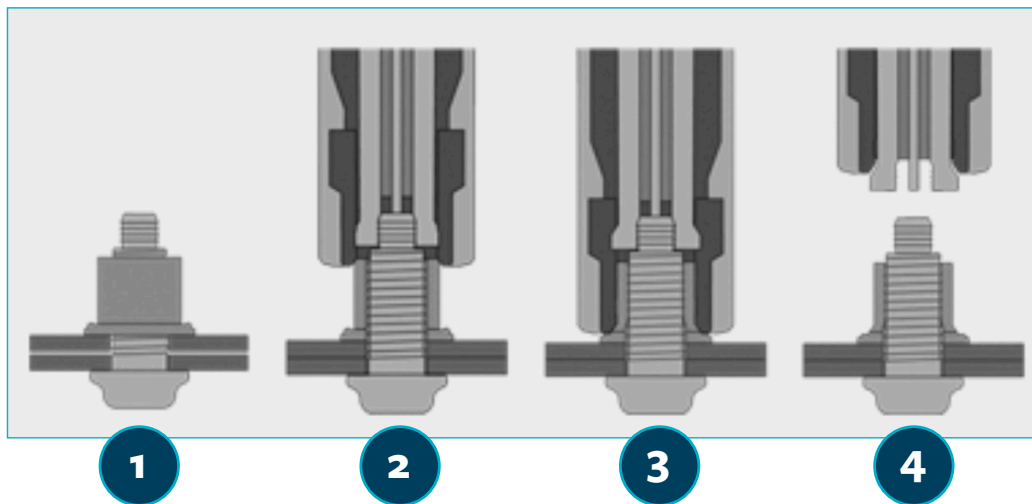

1. The pin is inserted into the prepared hole and the collar is pushed or spun onto the pin.
2. The installation tool is applied to the pull grooves. When the tool is activated, a puller in the nose assembly draws the pin into the tool, causing the swaging anvil to press on the collar, drawing up any sheet gap.
3. At a predetermined force, the anvil begins to swage the collar into the pins lock grooves. Continued swaging elongates the collar and pin, developing precise clamp.
4. When swaging of the collar into the pin lock grooves is complete, the tool ejects the fastener and releases the puller to complete the sequence.

It also eliminates creep or misalignment of component materials typically experienced when installing nuts and bolts in larger steel structures such as chassis.

1. Installation

LockBolts offer consistent installed values meaning that the joint performance is the same with each installation, demonstrated by **Fig.1**. Importantly, this rapid and repeatable installation process delivers consistent results without the need for skilled operators.

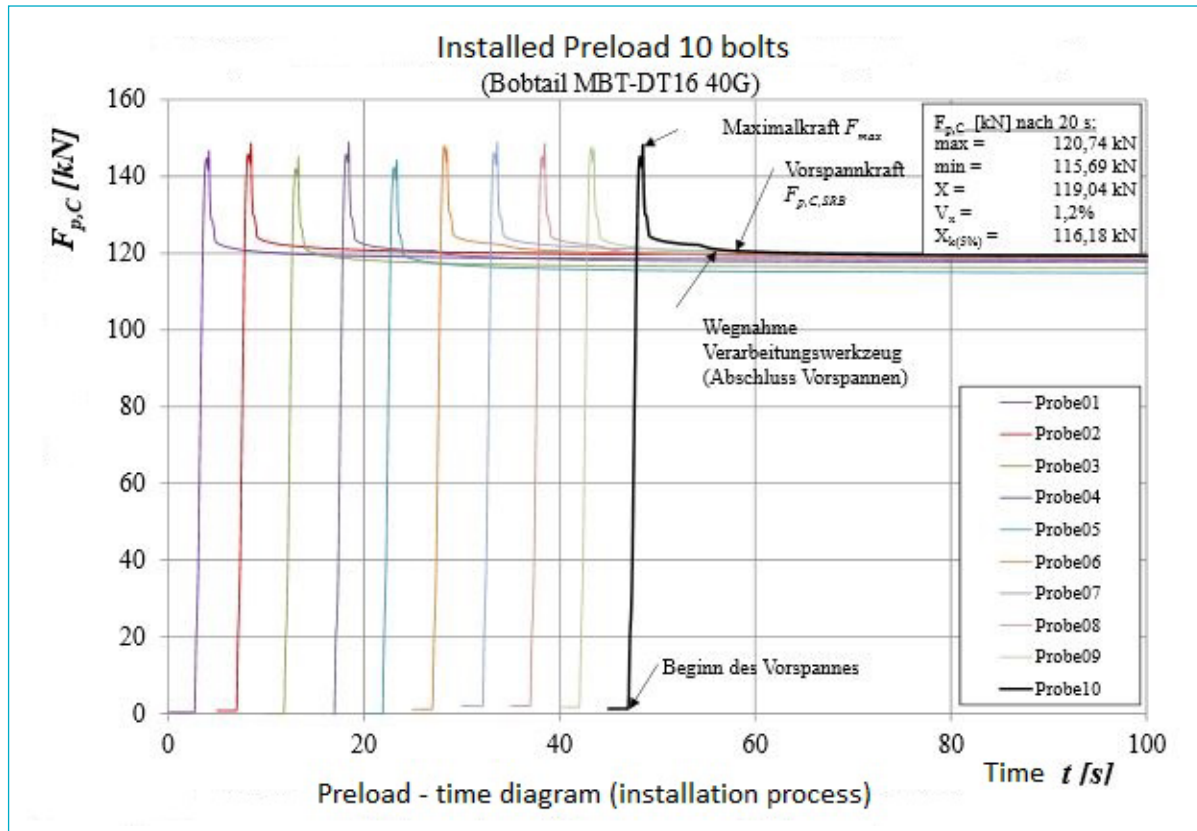

Fig.1

Once installed, the fastener will perform consistently for the lifetime of the trailer without requiring checking or retorquing.

The Huck LockBolt design has evolved over time and the installation process for its' newest product family, the BobTail, has been refined. This offers a quieter and easier installation using lighter, more ergonomic tooling as well as greater corrosion performance. BobTail also has a fit-up function where the collar can be pre-fitted over the pin using helical grooves, allowing the fasteners to be positioned without the possibility of collar movement.

The LockBolt installation process also enables an unparalleled level of production flexibility, supporting customised and modular manufacturing processes due to quick setup and installation times and minimal tooling requirements. Unlike welding, LockBolt tooling can easily be moved, extended or adjusted to access hard to reach places. The availability of battery powered tooling, takes flexibility to the next level, meaning LockBolts can be installed anywhere on your vehicle and in any production environment.



2. Joint Performance

The technical aspects of the joint, performance attributes and long-term implications.

Welding

There remain certain applications where welding is still the most viable option. For example, where the protrusions associated with fastenings are not acceptable. A perfect welded joint is very strong, but the challenge is guaranteeing consistent joint performance. That is one of the primary reasons why there is a general shift away from welded joints to more controlled, repeatable and modular alternatives which deliver the requisite level of strength but eliminate the variability of human skill.

From a technical and metallurgical standpoint, the heat generated by welding can often reduce the strength of the metals being joined and damage anti-corrosion surface coatings. This means additional care needs to be taken and post-fabrication processes, such as coating or painting, may be required. Welding can also be less effective in certain applications with excessive material thickness, material hardness and the joining of dissimilar materials (especially those with different coefficients of thermal expansion).

Weld quality issues may not always be visible or immediate, and the spectre of latent failure in the field is not something that is acceptable in a sector where long-term performance is a matter of safety. Small, initially non-problematic flaws in a weld can grow to become serious issues, possibly even leading to the complete failure over an extended period. The combination of harsh, aggressive and corrosive environments that trailers are subjected to, coupled with flexing and shock loading, can compromise the integrity and quality of a welded joint.

Nuts & bolts

The joint performance of nuts and bolts, if correctly

selected and installed, can be acceptable immediately following initial assembly. There is tooling available which will enable relatively consistent joint performance.

However, long-term joint performance is less predictable and can vary depending on factors such as installation errors, coating thickness variations as well as hole and material preparation.

Nut and bolt joint performance is more unpredictable when subjected to vibration and thermal cycling, although locking nuts do offer some protection against these forces. Unfortunately, unlike welding and LockBolts it is difficult to guarantee the long-term integrity of the joint; something which is critical in certain trailer applications.

Lockbolts

Huck LockBolts are designed to provide an incredibly consistent joint permanence every time. The dedicated swaging process eliminates the inconsistencies associated with welding and nuts and bolts.

Once installed, LockBolts have proven to be impervious to the vibratory conditions synonymous in a truck chassis during normal use. This is in contrast to conventional nut and bolt installations which can loosen in high-vibration environments. The reason for this can be seen by looking at the gaps between the nut and bolt threads of conventional fasteners when compared with a LockBolt.

The design features a collar that is fully swaged into the locking grooves of the pin; the direct metal-to-metal contact eliminates the transverse vibration often found in conventional nuts and bolts that may lead to loosening.

2. Joint Performance

See below cross-sections of the two fastening methods:

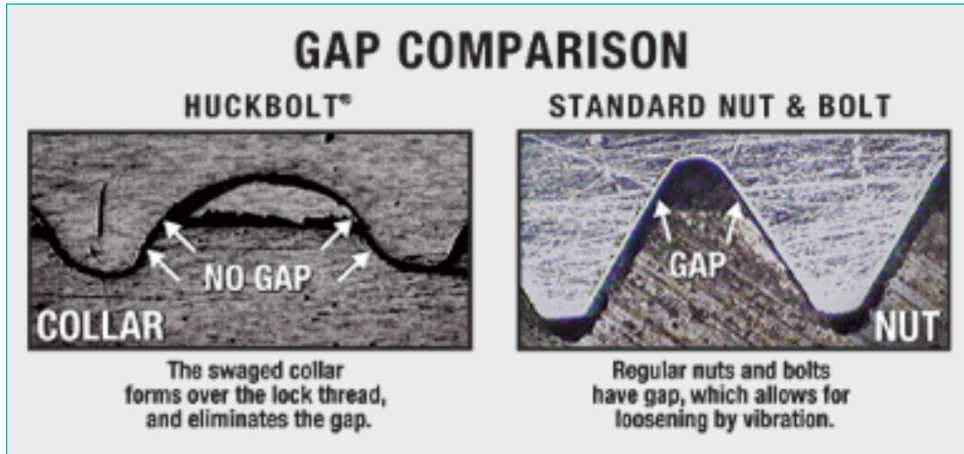

Instead of the deep threads needed to achieve a tolerance fit between conventional nuts and bolts, Lockbolts only require shallow locking grooves into which the collar is swaged. This shallow design allows for a larger pin radius, contributing to improved fatigue strength; up to five times that of a conventional nut and bolt (see Fig.2).

Evaluation fatigue tests Initial Inspection

Revision 03 - constant mean load = 293,1 kN (equals clamp load)

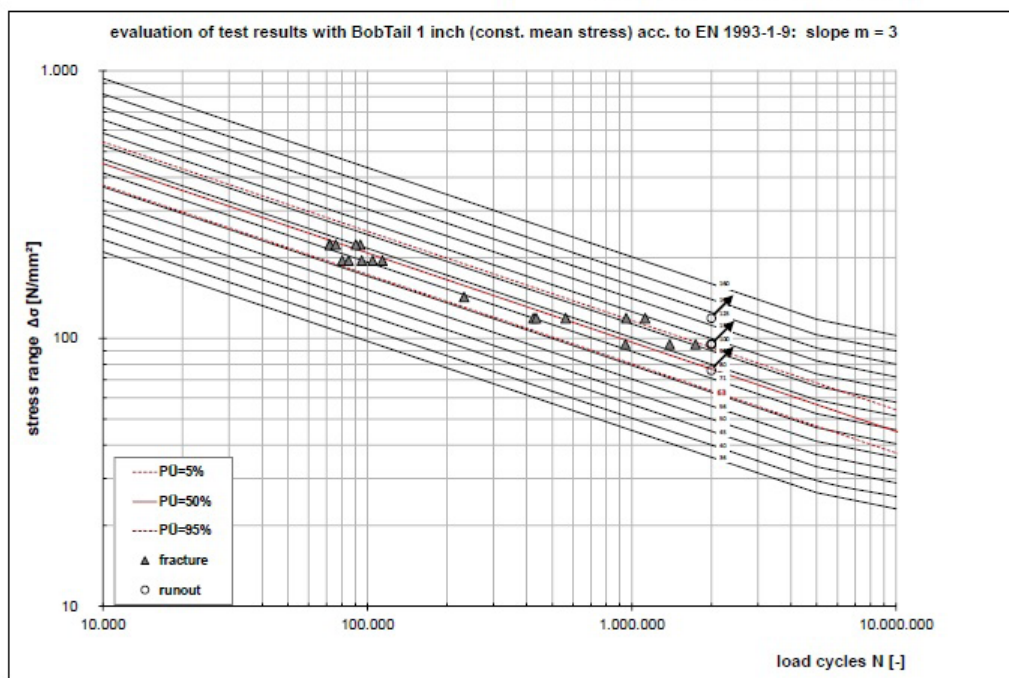

Fig.2



3. Lifetime Cost

The overall joint cost relative to performance, and short-term and long-term implications.

In the trailer industry, medium to high volumes may lead to manufacturers considering making very significant capital investments in large fixtures and robotic MIG welding equipment to streamline and control the fabrication process. However, a significant amount of relatively expensive, semi-skilled labour is still needed to first set-up, and then monitor, the automated welding process. Fabrication by welding is also very time consuming and potentially expensive for this reason, even when using robots, so the high-volume throughput needed to offset the capital outlay may be hard to achieve.

Where automation of the welding process cannot be justified is that very skilled, experienced, often highly paid, operators are needed. The costs are further increased as close inspection of finished welds is commonly a quality control and product safety requirement. Any inspection to look beyond surface defects at the internal integrity of the weld will require specialist equipment and operators.

Later, at points in the working life of the trailer, periodic inspection processes may be advisable. Arduous operating conditions including temperature cycling, vibration and exposure to salt spray and chemicals may all contribute to making what was a small, maybe invisible flaw immediately after production, turn into something more serious if unchecked.

In summary, although welding consumables are relatively low cost, the equipment, dedicated safe environment, skilled technicians and longer time taken, all mean that the total cost of ownership when using welding for a trailer chassis, is typically high.

Nuts & bolts

In the trailer market, nuts and bolts offer a relatively low-cost alternative to welding. Little skill is required for assembly (versus welding) and the parts are readily available at low cost. They can be more difficult to install correctly where creep or misalignment of materials

occurs, a common problem with nuts and bolts.

However, once out in the field where the joints are subjected to vibration and temperature cycling, something experienced in normal use in the trailer market. These conditions may have an adverse impact on the fatigue life of the joint over time so, although the initial cost of an installed nut and bolt joint may be the lowest out of the three methods addressed here, over the lifetime of the trailer there remains the risk of additional cost. However, compared to a weld, repairs and maintenance are easier and cheaper to carry out.

Lockbolts

Recognising the cost associated with assembly time, LockBolts installations are extremely fast; typically just two seconds. The time saving by utilising LockBolts is significant when considering the large number of fastening points on a trailer chassis. Post-installation, Huck LockBolts only require quick visual inspection, saving more time and cost.

Most importantly, and in contrast to conventional nut and bolt installations which can be unpredictable in high-vibration environments, LockBolts are impervious to the vibratory conditions synonymous in a trailer chassis during normal use. This means zero in-service inspection requirements, no downtime and no latent costs.

Whilst dedicated installation tooling is required to install LockBolts and the price per fastener may be a little more than nuts and bolts, the high fatigue strength of LockBolts also means that you can use fewer fasteners to assemble your chassis than ever before, whilst achieving the same levels of joint integrity. The initial overheads are quickly saved in other areas, making it one of the lowest cost fastening methods over a trailer lifetime based upon tests carried out over a 20 year period (Fig.3).

3. Lifetime Cost

LockBolts are considered by many to be a true 'fit-and-forget' solution.

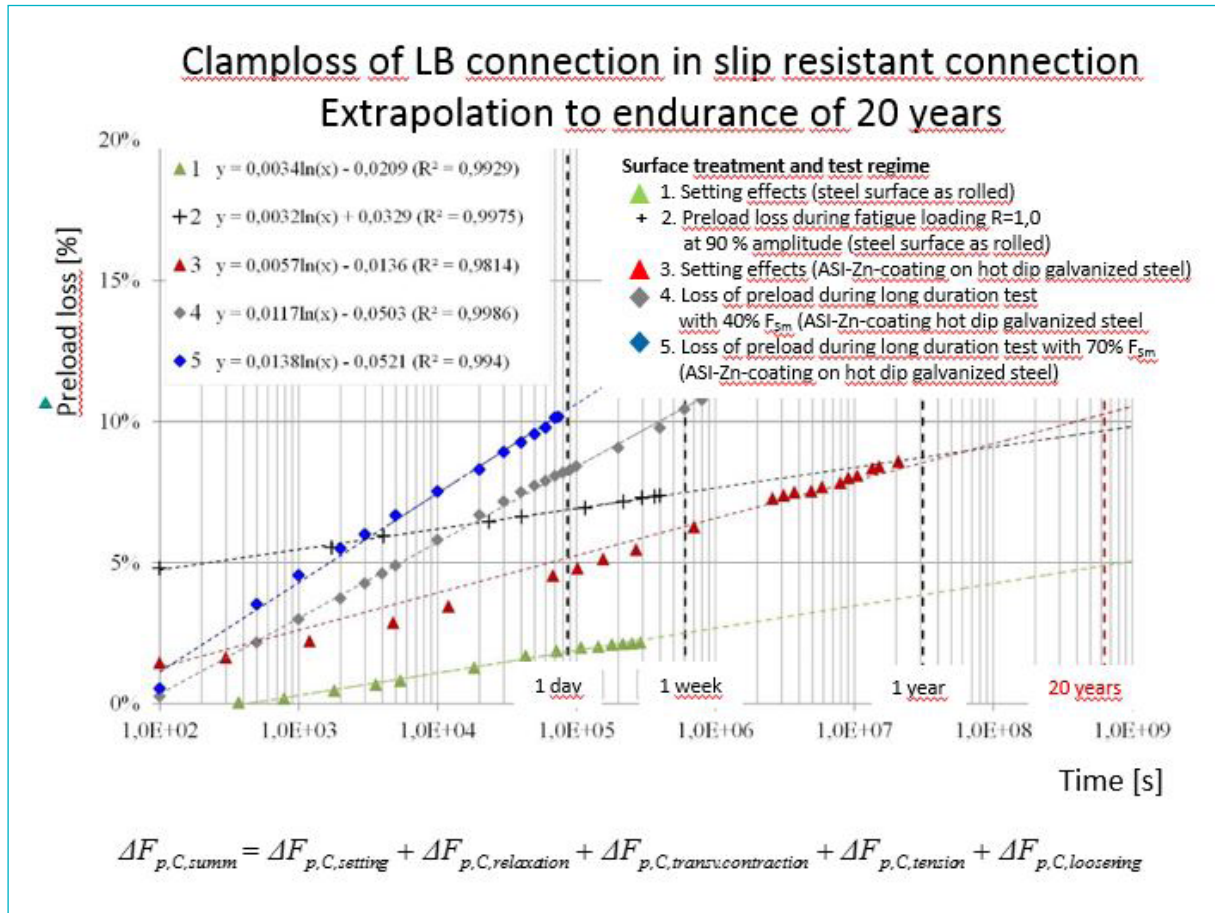

Fig.3

4. Summary and conclusions

Both welding and nuts and bolts have the advantage of being time proven fastening solutions for trailer applications. LockBolts, of the three joint fastening methods discussed in this whitepaper, are the least well-known.

However, as trends towards environment, health and safety as well as quicker vehicle assembly times have accelerated, so has the popularity of LockBolts. This is mainly due to their vibration proof performance and installation speed. LockBolts offer particular benefits

where a modular approach to assembly is utilised, offering the performance and flexibility to fasten the core modular chassis components together with great efficiency.

There will certainly remain a place for traditional fastening methods in future trailer assemblies but as vehicles evolve, the advantages of LockBolts and other advanced fastening technologies should not be overlooked.



About Howmet Fastening Systems

Part of Howmet Aerospace Engineered Products and Solutions, Howmet Fastening Systems is a global leader in the development and manufacture of innovative fasteners in a range of materials to serve markets including aerospace, industrial gas turbines, automotive, commercial transportation vehicles and construction and industrial equipment.

The company boasts many famous and long-standing brands, that are instantly recognisable and trusted names in industry. They have, and continue, to provide engineers within target markets with high-performance, dependable, cost-effective and easy-to-use fastening systems. In response to the evolving challenges that various sectors face, Howmet Fastening Systems uses its engineering experience and unrivalled technical know-how to continually evolve its product offering.

can provide an overall lower installed cost (total cost of ownership).

For more information about lockbolts from Howmet Fastening Systems and additional related reading visit:

<https://www.hfsindustrial.com/brands/huck.html>



Huck – a Howmet Fastening Systems brand, developed and patented the BobTail® System (lockbolt fasteners and tooling). The system represents the most advanced fastening technology to date. It has been

developed to deliver the highest levels of performance and reliability. BobTail lockbolts offers safe, quiet installation technology in an advanced HuckBolt design. BobTail is designed to deliver superior joining strength in even the most extreme environments.

Available in a wide range of sizes and grades, BobTail also offers quick and easy installation, and up to 10 times the fatigue strength of conventional nuts and bolts. When considering the cost of the fasteners with installation and inspection labour, BobTail lockbolt fasteners from Howmet Fastening Systems





Howmet Fastening Systems Ltd.
Unit C, Stafford Park 7, Telford TF3 3BQ
Tel : +44 (0) 1952 204 603
Fax : +44 (0) 1952 204670
Email : enquiries@hfsindustrial.com
Web : www.hfsindustrial.com

