

Huck® Structural Blind Fasteners

Stainless Steel Auto-Bulb™



Attractive, rounded bulbing on blind side minimizes snag risk

Tapered tip: for easy introduction into the blind hole

Large blind side footprint: ideal for lower strength or thin sheet joint material

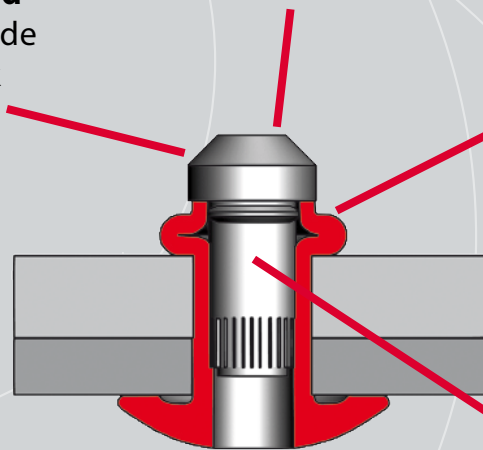

Recessed pin break on installation side means less risk of catching clothes or skin or the installed fastener

High corrosion resistance: stainless steel (400) enables use in applications operating in corrosive or hygienic environments including white goods and agriculture

Typical values

Shear: 15.1 kN

Tensile: 8.45 kN

Pin retention: 1.33 kN

Part Number	Diameter (mm)	Min. Hole size (mm)	Max. Hole size (mm)	Min. Grip (mm)	Max. Grip (mm)	Nom. F (mm)	Nom. L (mm)
ABP-4U8-M2	6.4	6.63	6.91	1.5	3.5	15.05	10.85
ABP-4U8-M3	6.4	6.63	6.91	2.8	4.8	16.35	12.15
ABP-4U8-M4	6.4	6.63	6.91	3.8	5.8	17.35	13.15
ABP-4U8-M5	6.4	6.63	6.91	4.8	6.8	18.35	14.15
ABP-4U8-M6	6.4	6.63	6.91	5.8	7.8	19.35	15.15
ABP-4U8-M7	6.4	6.63	6.91	6.8	8.8	20.35	16.15
ABP-4U8-M8	6.4	6.63	6.91	7.8	9.8	21.35	17.15
ABP-4U8-M9	6.4	6.63	6.91	8.8	10.8	22.35	18.15
ABP-4U8-M10	6.4	6.63	6.91	9.8	11.8	23.35	19.15
ABP-4U8-M12	6.4	6.63	6.91	11.8	13.8	25.35	21.15
ABP-4U8-M19	6.4	6.63	6.91	18.8	20.8	32.35	28.15

