

marson *HP-3 Professional HAND RIVET TOOL*
39002

PARTS LIST

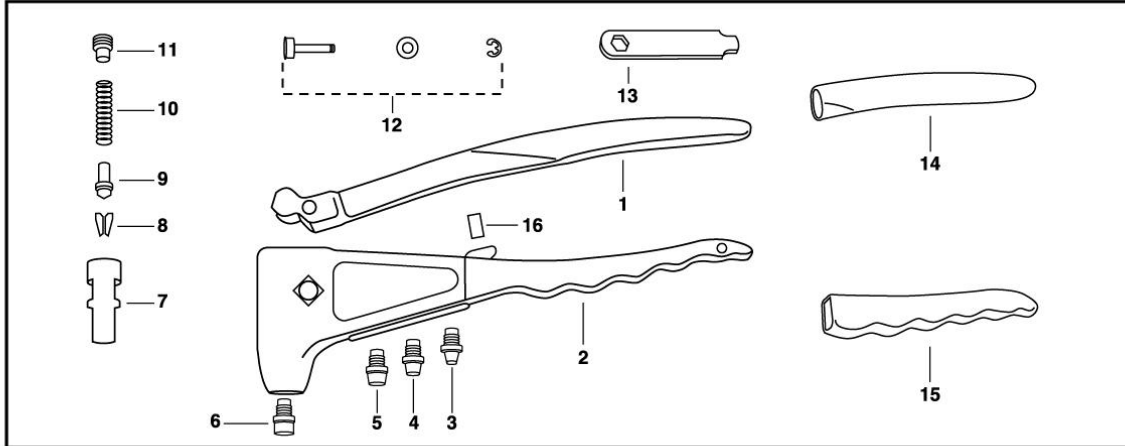

NO.	PART NO.	PART NAME	NO.	PART NO.	PART NAME
1	M39190	UPPER HANDLE	10	M39125	JAW PUSHER SPRING
2	M39191	ALUMINUM BODY	11	M39126	RETAINING SCREW
3	M39131	NOSEPIECE, 3/32" or 2.4mm	12	M39195	FULCRUM PIN
4	M39128	NOSEPIECE, 1/8" or 3.0/3.2mm			FULCRUM PIN BEARING
5	M39130	NOSEPIECE, 5/32" or 4.0mm			SNAP RING
6	M39129	NOSEPIECE, 3/16" or 4.8/5.0mm	13	M39137	WRENCH
7	M39122	COLLET CASE	14	M39192	UPPER GRIP
8	M39123	JAWS (2-PC TYPE)	15	M39193	LOWER GRIP
9	M39124	JAW PUSHER	16	M39194	SHOCK ABSORBER

NOTES: Please order parts by Part Number and Part Name.

OPERATION INSTRUCTIONS

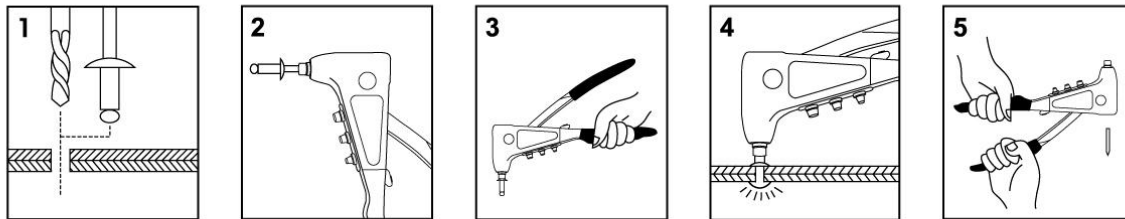

1. After selecting the correct Rivet for installation, drill the recommended hole size.

2. Open Tool Handle fully and insert Rivet Mandrel all the way into Tool Nosepiece.

3. Tool Working Nosepiece can hold Rivet Mandrel in any position for convenient use.
NOTE Hold the Aluminum Body, not the Upper Handle, to keep Rivet Mandrel.

4. Insert Rivet Body into the drilled hole completely. Squeeze Tool Handle until Rivet Mandrel breaks off. If more than one squeeze is required, open Tool Handle fully and squeeze again.

5. Finally open Tool Handle fully to eject spent Mandrel from Tool, either from Working Nosepiece or from upper side.

HOW TO CHANGE JAWS, JAW PUSHER, ETC. PARTS

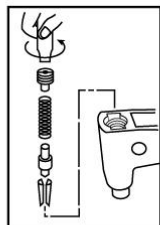

1. Close Tool Handle completely.
2. Remove Retaining Screw with Wrench, then remove Jaw Pusher Spring, Jaw Pusher and Jaws from Collet Case.
3. Clean jaws. If Jaw teeth are worn out, replace them. Before assembly, lubricate back side of Jaws with a film of light machine oil.

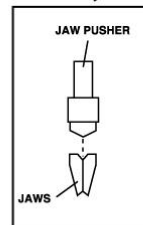

4. Reverse the above steps to reassemble, making sure that bevelled end of Jaw Pusher fits into the bevel provided by the Jaws.

WARNING

