

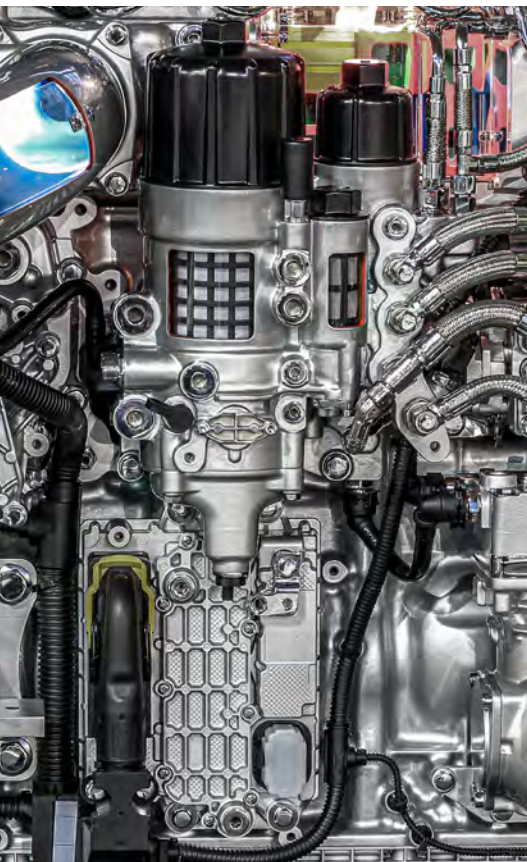

# Aftermarket Fasteners and Tools Catalog

MAY 2023







**HOWMET  
AEROSPACE**

## The Mechanic's Choice

**FIX-A-THRED®**

**marson**

**HUCK**

Howmet Fastening Systems offers the most versatile line of aftermarket repair fasteners and tools on the market today.

Go-to brands like Fix-A-Thred® thread repair products, industry-standard Marson® rivets and tooling, heavy-duty Keysert® thread inserts and precision-engineered Huck® fasteners and tooling are among the top names repair shop managers keep on hand to service trucks, trailers, cars and more.

The best aftermarket toolboxes are always stocked with the most durable and trusted lines of repair products in the industry.



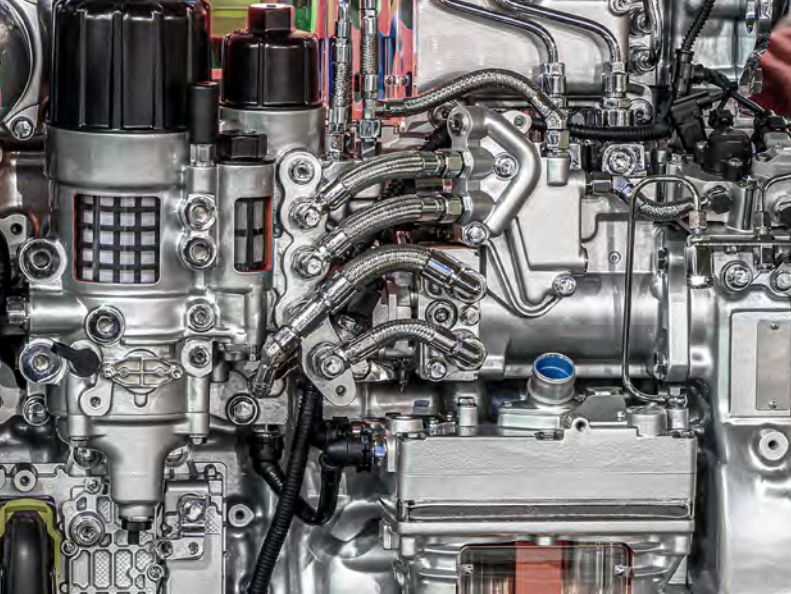

## **FIX-A-THRED®**

Introduction . . . . .	4
How It Works / Installation . . . . .	5
Thread Repair Kits . . . . .	6
Spark Plug Port Repair Kits . . . . .	8
Specialty Products . . . . .	10
Keysert® Inserts . . . . .	12
Extracting Tools . . . . .	14



## **marson**

Plastic Rivet Tools . . . . .	14
Introduction . . . . .	15
Hand Rivet Tools . . . . .	17
Air and Battery Tools . . . . .	20
Open End Rivets . . . . .	24
Closed-End, Klik-Lock Structural Rivets . . . . .	26
Multi-Grip Rivets, Plated Steel Mandrel . . . . .	27
Automotive, Special Application Rivets . . . . .	28
Klik-Lok™ Plastic Rivets . . . . .	30
Rivet Nuts and Tools . . . . .	31
Rivet Nut Tools . . . . .	33
Rivet Nut Kits . . . . .	34
ML Series Ribbed Rivet Nuts . . . . .	35
MRN Series Flathead Rivet Nuts . . . . .	36
Poly-Nuts . . . . .	37
MNN-Neoprene Inserts . . . . .	38



## **HUCK**

Introduction . . . . .	39
Tools and Kits . . . . .	41

# FIX-A-THRED®

Whether it's repairing spark plug port threads, manifolds, oil pans, oxygen sensors or any other aftermarket repair application, Fix-A-Thread® repair products can tackle most any challenge.

Fix-A-Thread kits' stainless steel inserts set the standard for rugged durability and product quality. Ideal for automotive, truck, motorcycle, marine, snow mobile, lawn and garden equipment and more, the Fix-A-Thread product line is built for ultimate strength, easy installation, reliability and versatility.

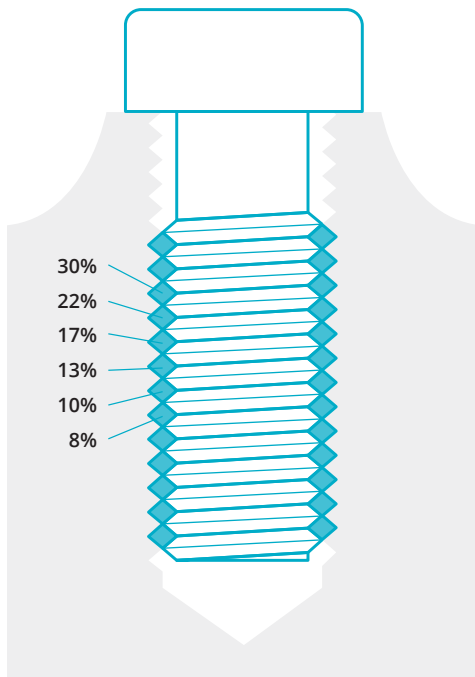

The spring-like design of the insert spreads the load over the entire bolt and the hole, reducing stud fracture and increasing holding or pull-out strength.

## How Fix-A-Thread® Works

Fix-A-Thread inserts are made from high-quality, 18-8 (type 304) diamond-shaped stainless steel wire. While the inserts are slightly larger in diameter than the tapped hole, the insert is compressed during installation, and then expands, permanently locking it into place.

Carbon Steel Tap





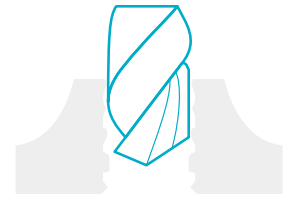
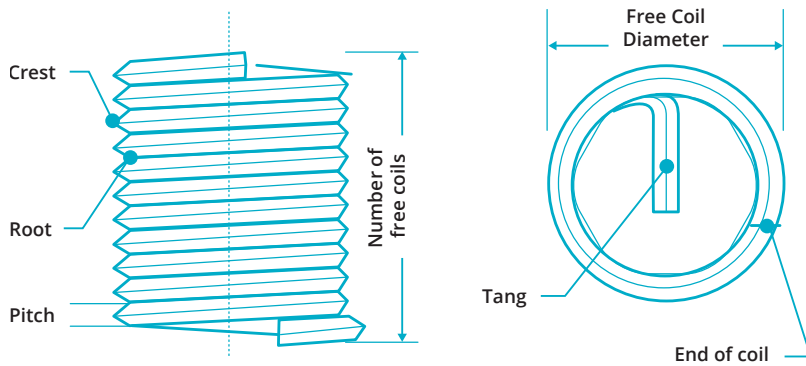

**1 DRILL THE HOLE**

Drill to clear out the damaged thread with drill size as specified on kit.

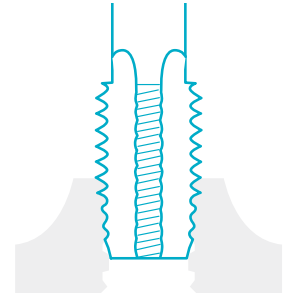

**2 TAP THE HOLE**

Using the correct size STI (Screw Thread Insert) tap and new 3-way tool, rethread the hole to accommodate the insert.

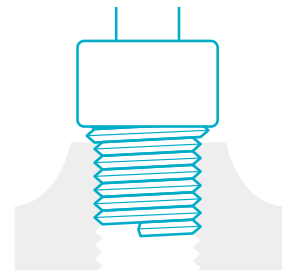

**3 INSTALL INSERT**

Insert in with downward pressure until the top coil is 1/4 to 1/2 turn below the surface. Drive the tang downward toward the bottom of the hole.

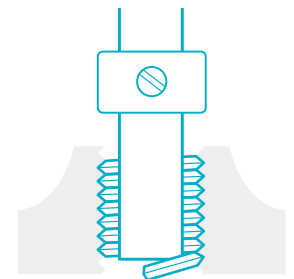

**4 REMOVE TANG**

Remove the tool and sit back on top of tang. Tap down sharply. Do not try to twist tang off!



Note: For spark plug port repairs and large fine threads, use long needle nose pliers to remove the tang. For larger holes or when higher strength is required, inserts can be stacked for additional strength. Insert length is 1.5 times diameter (e.g.: 1/2" thread diameter is 3/4" long). For specialty applications, inserts are available to order in 1D and 2D lengths.

# Thread Repair Kits

Fix-A-Thread Repair Kits are available in a wide range of sizes for both Unified Inch Coarse (UNC) and Unified Inch Fine (UNF). Kits are available in 33 of the most popular sizes from #8 through 1½" UNC and #10 through 1½" UNF. Metric repair kits are available for coarse and fine threads from M.3 - .5 to M.20 - 2.5. Each handy plastic kit contains inserts, tap, installation tool and instructions. Individual refill inserts are available as well.

## Fix-A-Thread Inch Coarse Repair Kits / Packets

KIT PART NO.	DESCRIPTION (INCLUDING THREAD SIZE)	REPLACEMENT INSERT PART NO.	DRILL SIZE (INCH)
33589	8-32 UNC KIT - 12 Inserts	23589 - 12 Inserts	11/64
33609	10-24 UNC KIT - 12 Inserts	23609 - 12 Inserts	13/64
33629	12-24 UNC KIT - 12 Inserts	23629 - 12 Inserts	15/64
33049	1/4-20 UNC KIT - 12 Inserts	23049 - 12 Inserts	17/64
33059	5/16-18 UNC KIT - 12 Inserts	23059 - 12 Inserts	21/64
33069	3/8-16 UNC KIT - 12 Inserts	23069 - 12 Inserts	29/64
33079	7/16-14 UNC KIT - 6 Inserts	23079 - 6 Inserts	17/32
33089	1/2-13 UNC KIT - 6 Inserts	23089 - 6 Inserts	19/32
33099	9/16-12 UNC KIT - 6 Inserts	23099 - 6 Inserts	21/32
33109	5/8-11 UNC KIT - 6 Inserts	23109 - 6 Inserts	25/32
33129	3/4-10 UNC KIT - 4 Inserts	23129 - 4 Inserts	29/32
33149	7/8-9 UNC KIT - 6 Inserts	23149 - 1 Inserts	1 1/32
33169	1-8 UNC KIT - 6 Inserts	23169 - 1 Inserts	1 5/32
33180	1 1/8-7 UNC KIT - 5 Inserts	23189 - 1 Insert	1 9/32
33200	1 1/4-7 UNC KIT - 4 Inserts	23209 - 1 Insert	1 13/32
33220	1 3/8-6 UNC KIT - 4 Inserts	23229 - 1 Insert	1 13/32
33240	1 1/2-6 UNC KIT - 4 Inserts	23249 - 1 Insert	1 17/32

## Fix-A-Thread Inch Fine Repair Kits / Packets

KIT PART NO.	DESCRIPTION (INCLUDING THREAD SIZE)	REPLACEMENT INSERT PART NO.	DRILL SIZE (INCH)
34609	10-32 UNF KIT - 12 Inserts	24609 - 12 Inserts	13/64
34049	1/4-28 UNF KIT - 12 Inserts	24049 - 12 Inserts	17/64
34059	5/16-24 UNF KIT - 12 Inserts	24059 - 12 Inserts	21/64
34069	3/8-24 UNF KIT - 12 Inserts	24069 - 12 Inserts	25/64
34079	7/16-20 UNF KIT - 6 Inserts	24079 - 6 Inserts	29/64
34089	1/2-20 UNF KIT - 6 Inserts	24089 - 6 Inserts	33/64
34099	9/16-18 UNF KIT - 6 Inserts	24099 - 6 Inserts	37/64
34109	5/8-18 UNF KIT - 6 Inserts	24109 - 6 Inserts	41/64
34129	3/4-16 UNF KIT - 4 Inserts	24129 - 4 Inserts	49/64
34149	7/8-14 UNF KIT - 6 Inserts	24149 - 1 Inserts	57/64
34169	1-12 UNF KIT - 6 Inserts	24169 - 1 Insert	1 1/64
34160-14	1-14 UNF KIT - 6 Inserts	24163 -14 - 1 Insert	1 1/64
34180	1 1/8-12 UNF KIT - 5 Inserts	24183 - 1 Insert	1 5/32
34200	1 1/4-12 UNF KIT - 4 Inserts	24203 - 1 Insert	1 9/32
34220	1 3/8-12 UNF KIT - 4 Inserts	24223 - 1 Insert	1 13/32
34240	1 1/2-12 UNF KIT - 4 Inserts	24243 - 1 Insert	1 17/32

## Fix-A-Thread Metric Coarse Repair Kits / Packets

KIT PART NO.	DESCRIPTION (INCLUDING THREAD SIZE)	REPLACEMENT INSERT PART NO.	DRILL SIZE (MM)
35039	M3-.5 KIT - 12 Inserts	25039 - 12 Inserts	3.1
35049	M4-.7 KIT - 12 Inserts	25049 - 12 Inserts	4.1
35059	M5-.8 KIT - 12 Inserts	25059 - 12 Inserts	5.2
35069	M6-1 KIT - 12 Inserts	25069 - 12 Inserts	6.2
35079	M7-1 KIT - 12 Inserts	25079 - 12 Inserts	7.2
35089	M8-1.25 KIT - 12 Inserts	25089 - 12 Inserts	8.3
35099	M9-1.25 KIT - 12 Inserts	25099 - 12 Inserts	9.3
35109	M10-1.5 KIT - 12 Inserts	25109 - 12 Inserts	10.3
35119	M11-1.5 KIT - 6 Inserts	25119 - 6 Inserts	11.3
35129	M12-1.75 KIT - 6 Inserts	25129 - 6 Inserts	12.4
35149	M14-2 KIT - 6 Inserts	25149 - 6 Inserts	14.4
35169	M16-2 KIT - 6 Inserts	25169 - 6 Inserts	16.5
35189	M18-2.5 KIT - 6 Inserts	25189 - 6 Inserts	18.5
35209	M20-2.5 KIT - 4 Inserts	25209 - 4 Inserts	20.5





FAT5829

### Fix-A-Thred Metric Fine Repair Kits / Packets

KIT PART NO.	DESCRIPTION (INCLUDING THREAD SIZE)	REPLACEMENT INSERT PART NO.	DRILL SIZE (MM)
37089	M8-1 KIT - 12 Inserts	27089 - 12 Inserts	8.2
38109	M10-1 KIT - 10 Inserts	28109 - 12 Inserts	10.3
38119	M11-1 KIT - 6 Inserts	28119 - 6 Inserts	10.3
37109	M10-1.25 KIT - 12 Inserts	27109 - 12 Inserts	10.3
37119	M11-1.25 KIT - 6 Inserts	27119 - 6 Inserts	11.3
37129	M12-1.5 KIT - 6 Inserts	27129 - 6 Inserts	12.5
38149	M14-1.5 KIT - 6 Inserts	27149 - 6 Inserts	14.3
38169	M16-1.5 KIT - 6 Inserts	27169 - 6 Inserts	16.25

### Fix-A-Thred Jobber Merchandisers

INCH COARSE DISPLAY PART# FAT5820MERCH*		METRIC DISPLAY PART# FAT5829MERCH*		INCH FINE DISPLAY PART# FAT5825MERCH*	
ITEM NO.	SIZE	ITEM NO.	SIZE	ITEM NO.	SIZE
33049	1/4-20	35069	M6-1	34609	10-32
33059	5/16-18	35089	M8-1.25	34049	1/4-28
33069	3/8-16	35099	M9-1.25	34059	5/16-24
33079	7/16-14	35109	M10-1.5	34069	3/8-24
33089	1/2-13	37109	M10-1.25	34079	7/16-20
98141	M14-1.25	37119	M11-1.25	34089	1/2-20
23049	1/4-20	25069	M6-1	24609	10-32
23059	5/16-18	25089	M8-1.25	24049	1/4-28
23069	3/8-16	25099	M9-1.25	24059	5/16-24
23079	7/19-14	25109	M10-1.5	24069	3/8-24
23089	1/2-13	27109	M10-1.25	24079	7/16-20
98142P	M14-1.25	27119	M11-1.25	24089	1/2-20
98143P	M14-1.25	* Each specific merchandiser contains one each of items listed. Jobber merchandisers require minimum space and can be displayed on counter or on peg board.			
98144P	M14-1.25				



FAT5820



FAT5825



FAT5820MOB



FAT5829MOB

### Fix-A-Thred Mobile Jobber Displays

INCH COARSE FAT5820MOB		METRIC COARSE FAT5829MOB	
PART NO.	DESCRIPTION	PART NO.	DESCRIPTION
33049	1/4-20 Repair kit	35069	M6x1 Repair kit
33059	5/16-18 Repair kit	35089	M8x1.25 Repair kit
33069	3/8-16 Repair kit	35099	M9x1.25 Repair kit
33079	7/16-14 Repair kit	35109	M10x1.5 Repair kit
33089	1/2-13 Repair kit	37109	M10x1.25 Repair kit
98141	Plug-Saver	387119	M11x1.25 Repair kit

Mobile jobber displays require minimum display space. For other sizes and replacements, see full catalog or current price sheet.

# Spark Plug Port Repair Kits

There is a Fix-A-Thread product for almost any spark plug type. Our standard Fix-A-Thread spark plug port repair kit, featuring stainless steel wire inserts, is designed to repair any gasketed spark plug port (for sizes M10-1, M12-1.25, M14-1.25 and M18-1.5). Another Fix-A-Thread product, the Plug-Saver spark plug port thread repair kit, uses solid steel inserts to repair the plug ports for both taperseat and gasketed plugs.

## Using Fix-A-Thread Plug-Saver Kits (Solid Inserts)

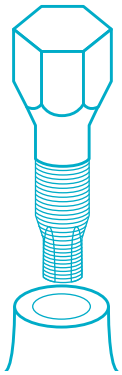

### 1 TAP

Pack tap with heavy grease. Hand start tap, then turn with socket wrench to tap hole full depth. Remove chips from hole.

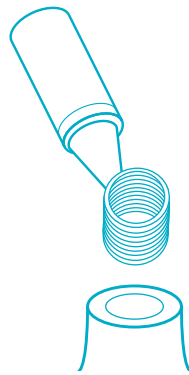

### 2 SELECT INSERT

Make certain selected insert is same length as the threads on the spark plug. The knurled end of the insert should be at the top of the spark plug hole. Coat outside threads with a high-temperature RTV silicone.

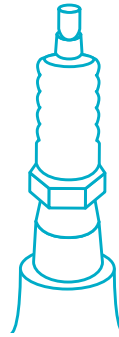

### 3 INSTALL INSERT

Screw insert in until flush with top of threaded hole. Insertion may be more easily facilitated by using the spark plug where the hole is recessed.

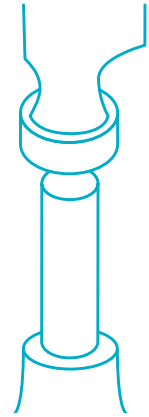

### 4 FINISH

Place expansion tool into insert and hit several times to expand the knurl. Install the spark plug to recommended torque. Do not run engine until sealant has set (refer to manufacturer's specifications).

## Fix-A-Thread Spark Plug Replacement Inserts

PART NO.	REFERENCE NO.	REFERENCE NO.	DESCRIPTION
98149P	R5326-14E	N/A	M14-1.25 Ford Triton Half Thread Plug-Saver - 8 Inserts
98142P	R5326-14S-6	2214-S	M14-1.25 Plug-Saver Short Reach - 5 Inserts
98143P	R5326-14N-6	2214-N	M14-1.25 Plug-Saver Normal Reach - 5 Inserts
98144P	R5326-14L-6	2214-L	M14-1.25 Plug-Saver Long Reach-5 Inserts
98146	-	-	Plug-Saver Expanding Tool
98147P	-	-	Plug-Saver Replacement Inserts-M14 -1.25; Short, Normal, Long Reach (2 Each)
9814750	-	-	Plug-Saver Swage Insert
9814760	-	-	Plug-Saver Install Insert
9814770	-	-	Plug-Saver Tap Extension
28109	R474-4	410-500	M12-1x1/2" Spark Plug Packet -10 Inserts
28122	R482-1	412-500	M12-1.25x1/2" Spark Plug Packet -10 Inserts
28123	R482-2	412-750	M12-1.25X3/4" Spark Plug Packet -10 Inserts
28140	R513-10	414-750	M14-1.25x3/4" Spark Plug Packet -10 Inserts
28147	R-513	414-43B	M14-1.25x7/16" Spark Plug Packet -10 Inserts
28148	R512	414-375	M14-1.25x3/8" Spark Plug Packet -10 Inserts
28149	R513-13	414-500	M14-1.25x1/2" Spark Plug Packet -10 Inserts
28189	R514-6	N/A	M18-1.5x1/2" Spark Plug Packet -5 Inserts



## Ford Triton Plug-Saver Kit / Part No. 98140T

This Fix-A-Thred Plug-Saver kit is designed to specifically repair the spark plug ports in 4.6, 5.4 and 6.8 liter Ford Triton engines. This specially configured M14-1.25 Plug-Saver kit ensures the secure repair of the spark plug port threads in the Triton engine by providing a mechanically locked solid repair sleeve insert between the threads in the head and the “half-thread” taperseat spark plug. The Triton Engine Kit comes with a handy carrying case providing all parts necessary for quick and easy repair — piloted reamer tap, tap extension, installation tool and 8 inserts. Not designed for 3-valve Triton engines.



## Plug-Saver Kit / Part No. 98141

Designed to repair M14-1.25 spark plug ports with no drilling required, the Plug-Saver repair system has long been the choice of professional mechanics and engine rebuilders. Available in three thread lengths, the Plug-Saver insert's mechanical locking system ensures secure installation. Using Fix-A-Thred Plug-Saver systems is both quick and easy, and every kit includes three different length inserts, a pilot tap and expansion tool.

- Repairs worn, damaged or stripped threads.
- Can be successfully used with any alloy or cast-iron head.
- Kits available to fit M14-1.25 spark plug port threads, gasketed or tapered.
- Designed for use with almost any engine—automotive, motorcycle, marine, outdoor power equipment and more.



# Speciality Products

## Oxygen Sensor M18 Thread Repair Kit / Part No. 38189-1

The Fix-A-Thread Oxygen Sensor Thread Repair Kit contains all the tools necessary to permanently repair damaged oxygen sensor threads in the exhaust manifold. The kit, packaged in a sturdy case with all components needed, is designed for ease-of-use by professional mechanics and engine rebuilders as well as do-it-yourselfers.



## Motorcycle and Outdoor Power Equipment Repair Kits

Threaded motorcycle parts such as spark plugs, timing plugs, cylinder head bolts, oil pump drain plugs, engine case bolts, cam covers and others require specific thread repair tools, as do threaded parts found in such outdoor equipment as lawn mowers, chainsaws and trimmers. Special Fix-A-Thread kits can help maintain top performance with inserts designed to permanently repair damaged or stripped threads on motorcycles and a wide range of outdoor power equipment. These kits include cost-effective and easy-to-install wire inserts that create threads that are, in most cases, stronger than the original. Also available are threaded inserts that fit National Pipe Thread (NPT).

These Fix-A-Thread kits include all you need to make permanent thread repairs, including inserts, tap and installation tool.

## Specialty Application Kits

PART NO.	DESCRIPTION
38109	M10-1 Spark Plug Kit - 24 Inserts
35119S	M11-1.5 Headbolt Repair Kit - 12 Inserts
38129	M12-1.25 Spark Plug Kit - 12 Inserts
38149	M14-1.25 Spark Plug Kit - 6 Inserts
38188	M18-1.5 Spark Plug Kit - 5 Inserts
38189-1	M18-1.5 Oxygen Sensor Kit - 6 Inserts
98140T	M14-1.25 Plug-Saver Kit - Ford Triton - 8 Inserts
98141	M14-1.25 Plug-Saver Kit - 1 each insert S, N, L
34040-24	1/4-24 Harley-Davidson® Kit - 10 Inserts
34070-16	7/16-16 Harley-Davidson® Kit - 10 Inserts
34140-20	7/8-20X.330 Carb. Kit - 5 Inserts
34160-20	1-20X.325 Carb. Kit - 5 Inserts
36020	1/8-27 NPT Kit - 10 Inserts - National Pipe Thread
36040	1/4-18 NPT Kit - 10 Inserts - National Pipe Thread
36060	3/8-18 NPT Kit - 10 Inserts - National Pipe Thread
36080	1/2-14 NPT Kit - 5 Inserts - National Pipe Thread
36120	3/4-14 NPT Kit - 5 Inserts - National Pipe Thread



## National Pipe Thread Replacement Inserts

PART NO.	REFERENCE NO.	REFERENCE NO.	DESCRIPTION
26023	R327 - 2	318 - 2	1/8-27 NPT Packet -10 Inserts
26043	R327 - 4	318 - 4	1/4-18 NPT Packet -10 Inserts
26063	R327 - 6	318 - 6	3/8-18 NPT Packet -10 Inserts
26083	R327 - 8	318 - 8	1/2-14 NPT Packet - 5 Inserts
26123	R327 -12	318 -12	3/4-14 NPT Packet - 5 Inserts

## Additional Special Application Kits

PART NO.	REFERENCE NO.	REFERENCE NO.	DESCRIPTION
34110-16	5559-11	3424-1250	11/16-16 Cummins Head Bolt Kit -10 Inserts
24043-24	N/A	N/A	1/4-24 Harley Packet -10 Inserts
24073-16	N/A	N/A	7/16-16 Harley Packet -10 Inserts
37101	10/1/4647	3221-M10F-0250	M10-1.25x25 mm Japanese M/C Head Bolt -10 Inserts
28181X			Replacement Inserts for O2 Sensor Kit 38181X

## Thread Repair Range Kits

Fix-A-Thred Thread Repair Range Kits supply the professional mechanic with everything needed to repair a wide range of threads. All Range Kits come fully equipped with a tap, installation tool and various inserts — all contained in a durable carrying case.



Part No. 33019

PART NO.	DESCRIPTION
33019	Inch Coarse Range Kit — 1/4-20, 5/16-18, 3/8-16, 7/16-14, 1/2-13
34019	Inch Fine Range Kit — 1/4-28, 5/16-24, 3/8-24, 7/16-20, 1/2-20
35019	Metric Coarse Range Kit — M5-.8, M6-1, M8-1.25, M10-1.5, M12-1.75
37019	Metric Fine Range Kit — M5-.8, M6-1, M8-1.25, M10-1.25
38016	Motorcycle Kit — M6-1, M8-1.25, M10-1, M10-1.25, M12-1.25, M14-1.25
38017	Outdoor Power Equipment Kit — 1/4, 5/16; M5-.8, M6-1, M8-1.25, M14-1.25
90002	Inch Coarse Mini Range Kit — 1/4-20, 5/16-18, 3/8-16
90005	Metric Mini Range Kit — M6-1, M8-1.25, M10-1.5

# Keysert® Solid Inserts

Designed for such heavy-duty applications as over-the-road trucks, RVs and heavy equipment, Keysert® inserts provide an easy-to-install thread assembly that repairs or replaces damaged threads. Each Keysert features two or four locking keys. Only standard drills and taps are required for installation. These inserts create a positive mechanical lock that prevents rotation and the Keysert insert works in almost all automotive materials.

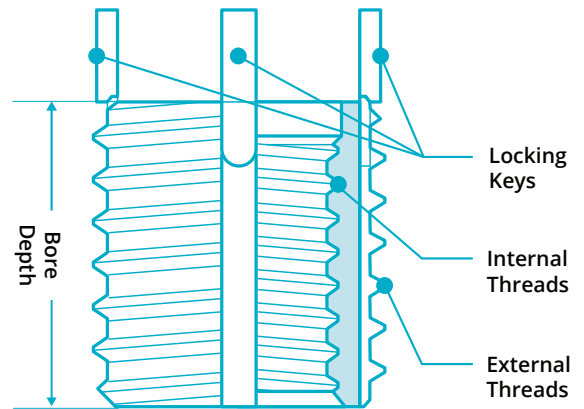

Each Keysert features two or four locking keys and are manufactured in carbon or stainless steel, in both inch and metric sizes.





# Keysert Installation

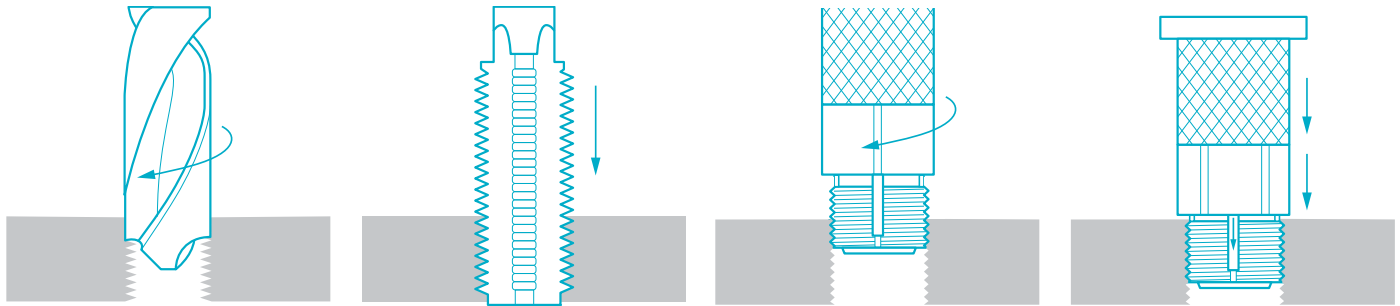

**1 DRILL**  
Drill out old threads with a standard drill.

**2 TAP**  
Tap new threads with a standard tap. See charts for proper size and depth.

**3 SCREW**  
Align the slots in the installation tool to fit over the keys, and screw in the insert until slightly below surface.

**4 DRIVE**  
Rotate installation tool so slots are not aligned with keys, and drive keys down with several hammer taps.



**The slotted installation tool** has slots that fit over the keys to twist insert into tapped threads and then stake down.



**The sleeve-style tool** has a sleeve that fits over the outside of the keys to keep them from splaying during the staking process.

## Range Kits

Inserts are sold in packets and in kits containing various insert sizes. Installation tools are available separately or in kits. See price list for full range of inserts and kits.

### Range Kits

KIT #	DESCRIPTION
72000	Tooling Range Kit
76003	UNC Carbon Steel Thinwall Range Kit
76004	UNC Stainless Steel Thinwall Range Kit
75003	Metric Coarse Carbon Steel Thinwall Range Kit
75004	Metric Coarse Stainless Steel Thinwall Range Kit
70003	UNC Carbon Steel Heavy Duty Range Kit
71003	UNF Carbon Steel Heavy Duty Range Kit
70004	UNC Stainless Heavy Duty Range Kit
71004	UNF Stainless Steel Heavy Range Kit
73003	UNC Carbon Steel Master HD Range Kit
74003	UNF Carbon Steel Master HD Range Kit
73004	UNC Stainless Steel Master HD Range Kit
74004	UNF Stainless Steel Master HD Range Kit



# Drill-Out®

## Drill-Out® Extracting Tools

Designed to quickly remove broken bolts and stripped screws, Drill-Out tools are available in a number of sizes: #5 and #6 (M6), #8 (M4) and #10 and #12 (M5), 1/4 inch (M6), 5/16 inch (M8), 3/8 inch (M12) and 1/2 inch (M16). The Drill-Out tool tip provides complete control and allows the user to obtain a perfectly centered hole without the tip "walking" or "wandering."



### Drill-Out Kits

PART NO.	DESCRIPTION	KIT CONTENTS
4017P	Drill-Out Kit (1 Each) - P250, P312, P375, P500	1/4" through 1/2", M6 - M12 extractors
4507P	Drill-Out Kit (1 Each) - P125, P164, P190, P236	No. 5 through 1/4" extractor

\*While Supplies Last

# Plastic Rivet Tool & Kit



## Klik-Lock® KL-2 Plastic Rivet Setter / M48005

This long-reach tool is just what today's professional needs for hard-to-reach spots, especially in automotive applications such as flexible bumpers, wheel wells, license plate brackets and bumper reinforcements. In addition to the tool's long reach, it offers one-stroke setting and a universal nosepiece that sets all plastic rivets. The tool is packaged in a reusable, heavy-duty vinyl pouch.

Weight: .75 lbs.

## Professional Plastic Rivet Kit / M48006

This kit includes the versatile KL-2 Plastic Rivet Setter, plus a 20-pack each of our four most popular rivet sizes: Nos. M58106, M58108, M58149 and M58150. A reclosable carton provides storage for rivets and tool.

Weight: 1.5 lbs.





## Rivets, Rivet Nuts & Tools

Over the years, Marson® products have built a reputation as one of the most respected brands in the aftermarket industry, offering a wide range of rivets, rivet nuts, installation tools (both manual and air-driven) and kits (including both rivets and tools). Marson products work hard in a wide variety of aftermarket fastening applications.



### Blind Rivets

Options include open-end, specialty, closed-end, multi-grip and high-quality plastic rivets made with strong nylon mandrels and Delrin 500 sleeves.

PAGE 27

### BT-5 Battery Tool

PAGE 22

### Blind Rivet Installation

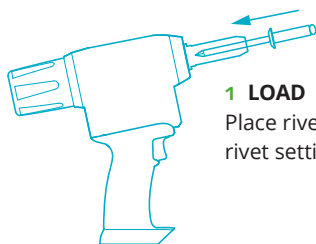

#### 1 LOAD

Place rivet mandrel in rivet setting tool.

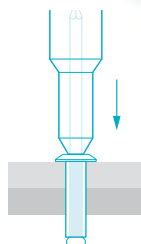

#### 2 INSERT

Using tool as a guide, insert rivet into prepared hole. Engage the mandrel with rivet-setting tool.

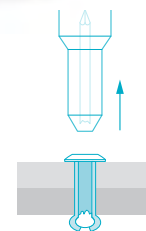

#### 3 SET

Squeeze trigger or handles to set rivet. Mandrel ejects after rivet is set.



### Rivet Nuts

Marson Rivet Nuts deliver low cost, permanent thread placement in thin material while providing at least six full thread turns per application install. Easy installation can be completed by one operator with minimum training. Rivet Nuts can be used to fasten multiple sheets as well as single sheets.

PAGE 36

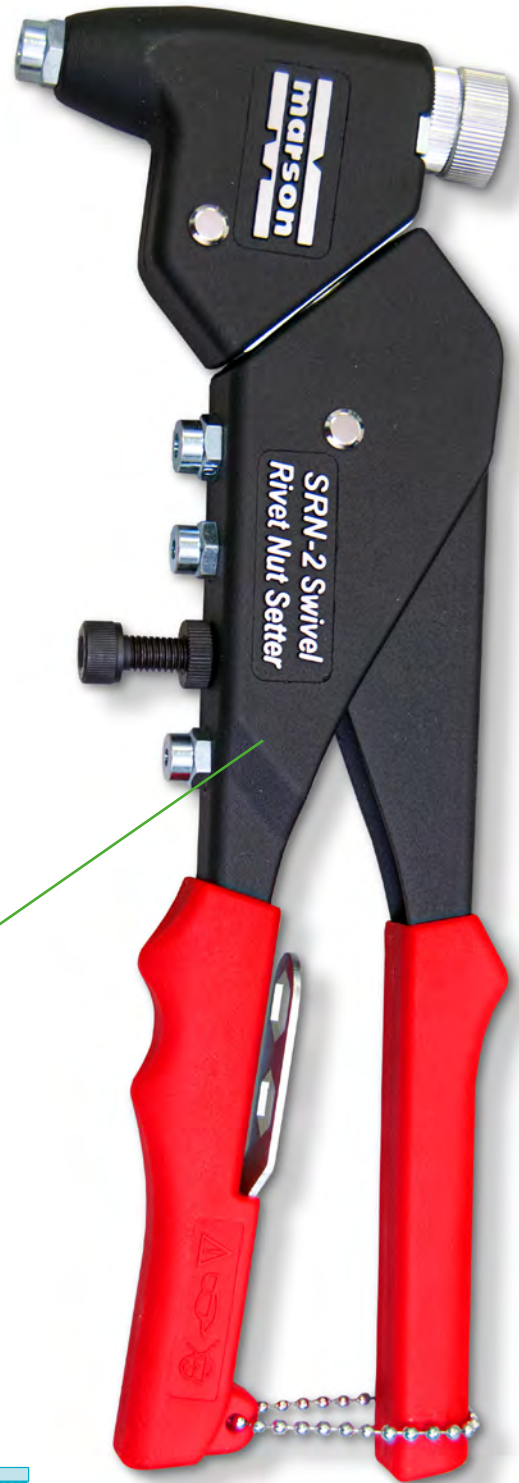

### SRN-2 Hand Rivet Nut Tool

PAGE 34

### Rivet Nut Installation

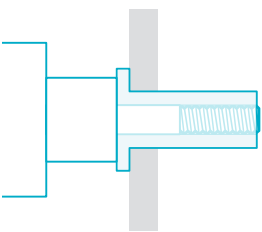

**1 INSERT**

Thread Rivet Nut onto tool mandrel and insert into hole.

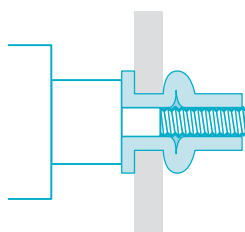

**2 INSTALL**

Actuate tool to properly set fastener into material.

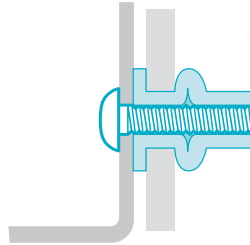

**3 ADD BOLT OR SCREW**

Complete your fastening operation with a bolt or screw with the proper thread. The positive riveting action of the Rivet Nut will provide a permanent thread. As threads are tightened, so are Rivet Nut and application.

# Hand Rivet Tools

## HP-2® / M39000

The HP-2 is the number one selling hand rivet tool in the industry. Known and trusted for durability, quality and performance, the HP-2 is often copied but never duplicated. Its square-shoulder fulcrum pin of cold-formed, heat-treated steel alloy prevents pin rotation that can elongate the engaging holes and cause premature tool failure in imitation tools. Other quality features include: precision die-cast, high-strength aluminum alloy body with steel insert for durability; drop-forged carbon steel upper handle; and thick, cushion-molded vinyl eco-friendly plastic grips for comfort. The HP-2 sets 3/32", 1/8" and 5/32" rivets in all materials and up to 3/16" steel rivets, and comes with four mounted nosepieces (3/32", 1/8", 5/32" and 3/16") and a service wrench. Refer to the Hand Rivet Tool Capacity Chart on page 31 for specific capabilities.

Weight: 1.2 lbs.



## HP-5™ / M39011

The HP-5 is specially designed for securing the rivet in the nosepiece while the tool is in any position. It has ergonomic handles with power-saving design and eco-friendly, soft-plastic grips to increase leverage, and deliver powerful riveting with 4 standard nosepieces changed with included service wrench to set 3/32", 1/8" and 5/32" rivets in all alloys and up to 3/16" in steel. The drop-forged steel handle is heat-treated, and the die-cast aluminum alloy body has a steel insert for durability. Has a strong anti-wearing fulcrum pin, durable jaws and jaw case, and valuable powder coating finish.

Weight: 1.22 lbs.



## 200 Kit™ / M39001

The deluxe hand riveter kit includes the HP-2 and 200 assorted Klik-Fast rivets in popular sizes. The molded plastic case houses and protects the tool, rivets and optional countersink double ended drill bit.

Weight: 4 lbs.



## Stainless Steel Kit / M39003

This kit is the same as our 39001, but contains 200 assorted Klik-Fast stainless steel rivets.

Weight: 4 lbs.

## HP-4x4™ Multiplex Kit / Inch M39410 / Metric M39411

The Marson HP-4x4 Multiplex hand tool is a new, patented design that allows a single tool to set Blind rivets (3/32" to 3/16") and rivet nuts. Simply change out the nose components to allow for quick conversion from blind rivets to rivet nuts.

Metric and Imperial thread kits are available:

**M39410** Inch thread kit includes rivet nut mandrels (6, 8, 10, 1/4-20) + MET series bolt/studs (8 and 10) thread.

**M39411** Metric thread kit includes rivet nut mandrels (M3, M4, M5, M6) + MET series bolt/studs (M4 and M5) thread.

Replacement mandrels sold separately.



## Klik-Turn® SP-2 / M39015

The SP-2 360° swivel head rivet tool features a patented positive-ratchet locking feature that allows head to turn 360° and lock in place at any of the 45+ positions. A patented Rivet Size Hole Gauge eliminates selection of the wrong size rivet size for a nosepiece. It's ideal for riveting in difficult places at any angle. The SP-2 includes 4 nosepieces, built-in storage holes and a service wrench. Sets up to 3/16" steel rivets.

Weight: 1.55 lbs.



## VHR-1 / M79000

This economic hand riveter offers all-steel construction, setting rivet sizes 3/32", 1/8" and 5/32" in all alloys and 3/16" in steel. Service wrench and locking tab included.

Weight: 1.2 lbs.



## VHR-1X/M79002

This hand rivet tool offers durable, all-steel construction and sets 3/32"-5/32" diameter rivets in all alloys and 3/16" in steel. The extended nosepiece can reach 1-3/4". Service wrench and locking tab included.

Weight: 1.2 lbs.



## VHR-2 / M79032

This value-priced tool sets 1/8" – 1/4" diameter rivets in all materials. It can also set T-Rivet / Klik-Split® and all other structural blind rivets. With its heavy-duty construction and longer handles, access to hard-to-reach areas is easier.

Weight: 2.5 lbs.

## Hand Rivet Tool Capacity

	STEEL					ALL ALUMINUM					ALUMINUM STEEL					STAINLESS					MONO-BOLT®*		"T" RIVETS			
	3/32"	1/8"	5/32"	3/16"	1/4"	3/32"	1/8"	5/32"	3/16"	1/4"	3/32"	1/8"	5/32"	3/16"	1/4"	3/32"	1/8"	5/32"	3/16"	1/4"	3/16"	1/4"	3/16"	1/4"		
HP-2 / M39000	•	•	•	•		•	•	•	•		•	•	•	•		•	•	•								
HP-5 / M39011	•	•	•	•		•	•	•	•		•	•	•	•		•	•	•								
SP-2 / M39015	•	•	•	•		•	•	•	•		•	•	•	•		•	•	•								
HP-4x4 / M39410	•	•	•	•		•	•	•	•		•	•	•	•		•	•	•								
BIG DADDY (All)		•	•	•	•		•	•	•	•		•	•	•	•		•	•	•	•	•	•	•	•	•	•
VHR-1 / M79000	•	•	•	•		•	•	•	•		•	•	•	•		•	•	•								
VHR-1X/M79002	•	•	•	•		•	•	•	•		•	•	•	•		•	•	•								
VHR-2 / M79032		•	•	•	•		•	•	•	•		•	•	•	•		•	•	•	•					•	•

Monobolt® is a registered trademark of Avdel® \* When setting Marson brand Klik-Lock rivets, no special nosepiece is required.

# Hand Rivet Tools

## Big Daddy® / M39031

The Big Daddy and Big Daddy II are the most versatile and powerful Marson brand hand riveters, taking the hard work out of setting large diameter blind rivets. Extra long handles provide superior leverage and permit working a foot beyond natural reach. Other features include a special bearing design, self-adjusting two-piece jaws and single-unit body construction with a steel insert to provide stronger threads for the nosepieces included. Both feature a double-gear reduction system which easily sets from 1/8" to 1/4" diameter Klik-Fast rivets in all alloys, including 1/4" Klik-Split® and 3/16" and 1/4" Klik-Lock® rivets. A one-piece collet case eliminates the need to adjust the tool when changing rivet diameters. Both Big Daddy and Big Daddy II come with 5/32", 3/16" and 1/4" nosepieces which are stored in the body.

Weight: 3.75 lbs.

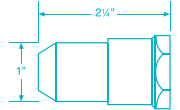

Standard head

## Big Daddy II / M39032

Exclusive to Big Daddy II: a built-in mandrel collection receptacle; just remove the end cap on the bottom handle to discard the spent mandrels.

Weight: 3.75 lbs.



## Big Daddy / M39010

This is the same tool as 39031, but comes with 3/16", 1/4" and special 1/4" Klik-Split rivet nosepieces.

Weight: 3.75 lbs.



## Big Daddy / M39035

This is the same tool as 39010, but comes with 39009 attached, extending the tool's reach by an additional 2-1/2".

Weight: 4 lbs.



Extended head

## Big Daddy Extended Nosepiece Kit / M39009

Just two installed parts extend the reach of 39031 or 39010 by an additional 2-1/2".

Weight: .25 lbs.



## Hand Rivet Tools — Standard and Special Nosepieces

	STANDARD					MONOBOLT®*		T-RIVET SIZES	
	3/32"	1/8"	5/32"	3/16"	1/4"	3/16"	1/4"	3/16"	1/4"
HP-2 / M39000	M39131	M39128	M39130	M39129					
HP-5 / M39011	M39131	M39128	M39130	M39129					
SP-2 / M39015	M39165	M39164	M39163	M39162					
BIG DADDY (All)		M96024	M96025	M96026	M96027	M96031	M96030	M96029	M96028

\* When setting Marson brand Klik-Lock rivets, no special nosepiece is required.

# Air & Battery Powered Rivet Tools

These next generation, professional series air / hydraulic riveters are designed to be lightweight and well-balanced. Both are engineered to maximize stroke and pull force with a 3-jaw set. For added convenience, you can direct connect or use the attached swivel. Each tool is supplied with nosepieces to set rivets in all alloys and comes complete with adjustment service wrenches, hydraulic fluid, fluid applicator, spare jaws and a removable swivel air connection line with an air OFF / ON valve built in. An adjustable vacuum system allows you to control the force of air needed to hold the rivet in place, or you may operate with the vacuum system turned off. Recommended air pressure is 70-95 psi.

Each of these proven, professional tools features a one-piece molded frame and front swivel air inlet for maximum operator comfort and durability. An external vacuum adjustment offers convenient air flow control for rivet placement and mandrel disposal. This allows the operator to install rivets in any orientation using one hand, and freeing up the other for assembly. Spent mandrels are conveniently collected in the bottle for disposal, encouraging a safer, clean work environment. Tools come complete with oil, replacement jaws and nosepieces. Recommended air pressure: 85-95 psi.



## M-3 / M39054

This heavy-duty air riveter with its thoughtfully designed aluminum forged head can hold up under demanding continuous use. The head allows for continuous full operating power and less internal wear. Included with the M-3 are standard 1/8", 5/32" and 3/16" nosepieces, a service wrench, swivel inlet air coupler and a mandrel collection bottle. The recommended air line pressure is 85-95 PSI.

**Stroke:** .551" (14 mm)

**Pulling Force:** 1,983 lbs. (8,820n)

**Capacity:** 1/8" (3.2 mm) to 3/16" (4.8 mm) in all alloys including some structural rivets

**Weight:** 4.2 lbs.



## M-4 / M39058

This heavy-duty air riveter with its thoughtfully designed aluminum forged head can hold up under demanding continuous use. The aluminum forged head allows for continuous full operating power and less internal wear. The M-4 has the capability of setting 3/16" and 1/4" T-Rivets/Klik-Split, Klik-Lock and all other structural blind rivets (special optional nosepieces may be required). The M-4 is supplied with 3/32", 5/32", 3/16" and 1/4" standard nosepieces, service tools, swivel inlet air coupler and a mandrel collection bottle. The recommended air line pressure is 85-95 PSI.

**Stroke:** .748" (19 mm)

**Pulling Force:** 3,500 lbs. (13,784n)

**Capacity:** 3/32" (2.4 mm) to 1/4" (6.4 mm) in all alloys including structural rivets

**Weight:** 6.6 lbs.





**MP-3V / M39045**

Stroke: 3/4"

Pulling Force: 1,800 lbs.

Capacity: 3/32" - 3/16", all alloys

Weight: 2.9 lbs.



**301-EN / M39065**

Stroke: 0.807"

Pulling Force: 2,360 lbs

Capacity: 3/32" - 3/16" diameter in all alloys; up to 1/4" in aluminum

Weight: 3.5 lbs.

Automatic Air-Stop: cuts vacuum draw when idle



**MP-4V / M39048**

Stroke: 1"

Pulling Force: 3,420 lbs.

Capacity: 5/32" - 1/4", all alloys, 1/4" Monobolt® nosepiece included

Weight: 3.7 lbs.



**304-E / M39064**

Stroke: 1"

Pulling Force: 4,200 lbs.

Capacity: 3/16" to 1/4" in all alloys, including structural rivets. Also included are 3/16" and 1/4" Monobolt® and Magna-Lok® assemblies

Weight: 5.5 lbs.



**IntegraFuse IF-1 / M39075**

Stroke: 1.125" (28.575 mm)

Pulling Force: 4,600 lbs. (20.5kn)

Capacity: 3/16" (4.8 mm) to 1/4" (6.4 mm)

Weight: 4.8 lbs. (2.177kg)



**Extended Head Accessory for 301-EN and 304-E**

301-EN / M39065	5" Extension Head	M88082
301-EN / M39065	8" Extension Head	M88086
304-E / M39064	5" Extension Head	M723358



### BT-5 / M38990

The Marson® BT-5 is among the best values you'll find anywhere for industrial-strength, battery-powered riveters. Engineered for dependability on the factory floor or at the job site, BT-5 delivers reliable performance at a fraction of the cost of other high-performance riveters.

The Marson BT-5 Kit includes nose tips for 1/8", 5/32" and 3/16" rivet diameters. An optional nosepiece allows you to install 3/32" rivets, as well.

**Stroke:** 0.866" (22 mm)

**Pulling Force:** 2,248 lbs. (10,000 n)

**Capacity:** 3/32" (2.4 mm) to 3/16" (4.8 mm)

**Weight (with Li-ion battery pack):** 4.21 lbs. (1.91 kg)

**Battery Pack:** 18 V / Li-ion / 2.0 Ah

**Recharge Time:** approx. 45 minutes



### BT-6 / M38996

The Marson® BT-6 is a battery-powered riveter designed to deliver reliable pull-force for high-volume assembly applications. Engineered for versatility and extensive use on factory floors and job sites, this portable powerhouse offers a durable value.

The Marson BT-6 kit includes nose tips for 3/16" and 1/4" rivet sizes.

**Stroke:** 1.1024" (26 mm)

**Pulling Force:** 4,496 lbs. (20,000 n)

**Capacity:** 3/16" (4.8 mm) to 1/4" (6.4 mm)

**Weight (with Li-ion battery pack):** 4.28 lbs. (1.91 kg)

**Battery Pack:** 18 V / Li-ion / 2.0 Ah

**Recharge Time:** approx. 45 minutes

### AH-250 / M39510

**Nose Assembly:** Optional part

**Stroke:** 0.728"

**Pulling Force:** 5,280 lbs.

**Capacity:** Standard Rivets 5/32" - 1/4"  
Structural Blind Rivets 5/32" - 1/4"  
C6L® and Magna-Grip® 3/16" - 1/4"

**Weight:** 5.58 lbs.



### MUNA 8™ Nose Assembly / M96557

Optional MUNA 8™ for AH-250 sets 5/32", 3/16", and 1/4" Blind Rivets, both Standard and Structural, simply by changing out the included Nosepieces.

### HUCK® Nose Assemblies

Optional HUCK® Nose Assemblies for AH-250 set Structural Blind Rivets 3/16" - 1/4" and C6L® and Magna-Grip® 3/16" - 1/4" lockbolts.





**V-2 / M79014**

Stroke: .551"

Pulling Force: 1,870 lbs.

Capacity: 3/32" – 3/16", all alloys

Weight: 3.5 lbs.



**V-3 / M79050**

Stroke: .551"

Pulling Force: 1,983 lbs.

Capacity: 1/8" – 3/16", all alloys

Weight: 3.2 lbs.



**V-4 / M79060**

Stroke: .562"

Pulling Force: 3,055 lbs.

Capacity: 3/32" – 1/4", all alloys

Weight: 4.4 lbs.

Recommended airline pressure: 85-95 PSI.

**Power Rivet Tools — Standard and Special Nosepieces**

	STANDARD					MONOBOLT®**	
	3/32"	1/8"	5/32"	3/16"	1/4"	3/16"	1/4"
M-3 / M39054		M95715	M95716	M95717			
MP-3V / M39045	M95200	M95201	M95202	M95203			
M-4 / M39050	M95897	M95898	M95899	M95900		M95904	M95906
MP-4V / M39048			M95300	M95301	M95302	M95299	M95303
301-EN / M39065	M717006	M717001	M717002	M717003	M717005		
304-E / M39064				M88220-1	M88220-79	M88220-85	M88220-84
BT-5 / M38990	M96208	M96209	M96210	M96211			
BT-6 / M38996			M96310	M96311	M96322		
IF-1 / M39075				M95137-2	M95137		
AH-250 / M39510			M96557*	M96557*	M96557*	M96557*	M96557*
V-2 / M79014	M95761	M95762	M95763	M95760			
V-3 / M79050		M95715	M95716	M95717			
V-4 / M79060	M95897	M95898	M95899	M95900	M95835		

\*AH-250 is also compatible with Huck Nose Assemblies. See the AH-250 flyer for additional details.

**Power Rivet Tools — Capacity**

	STEEL					ALL ALUMINUM					ALUMINUM STEEL					STAINLESS					STRUCTURAL**		
	3/32"	1/8"	5/32"	3/16"	1/4"	3/32"	1/8"	5/32"	3/16"	1/4"	3/32"	1/8"	5/32"	3/16"	1/4"	3/32"	1/8"	5/32"	3/16"	1/4"	3/16"	1/4"	
M-3 / M39054		•	•	•			•	•	•			•	•	•			•	•	•				
MP-3V / M39045	•	•	•	•		•	•	•	•		•	•	•	•		•	•	•	•				
M-4 / M39058	•	•	•	•	•	•	•	•	•	•	•	•	•	•	•	•	•	•	•	•	•	•	•
MP-4V / M39048			•	•	•			•	•	•			•	•	•			•	•	•	•	•	•
301-EN / M39065	•	•	•	•	•	•	•	•	•	•	•	•	•	•	•	•	•	•	•	•	•	•	•
304-E / M39064				•	•				•	•				•	•				•	•	•	•	•
BT-5 / M38990	•	•	•	•		•	•	•	•		•	•	•	•		•	•	•	•				
BT-6 / M38996				•	•				•	•				•	•				•	•	•	•	•
IF-1 / M39075				•	•				•	•				•	•				•	•	•	•	•
AH-250 / M39510			•	•	•			•	•	•			•	•	•			•	•	•	•	•	•
V-2 / M79014	•	•	•	•		•	•	•	•		•	•	•	•		•	•	•	•				•
V-3 / M79050		•	•	•			•	•	•			•	•	•			•	•	•				•
V-4 / M79060	•	•	•	•	•	•	•	•	•	•	•	•	•	•	•	•	•	•	•	•	•	•	•

\*\*For Monobolt® structural rivets, the noted special nosepiece is required. For Marson brand Klik-Lock® structural rivets, no special insert is required.



# Open-End Structural Rivets



## Features & Benefits

- For blind fastening where there is no access to opposite side of work
- Simple to install
- Wide variety of head styles and lengths available from 3/32" to 1/4" diameters

## Materials Available

Steel / steel, Aluminum / aluminum, Aluminum / steel, Stainless / stainless, Stainless / steel, Copper / brass, Copper / steel

## Open-End Rivets

RIVET DIA	GRIP RANGE	HEAD DIA	PLATED STEEL RIVET STEEL MANDREL			STAINLESS STEEL RIVET STAINLESS STEEL MANDREL			STAINLESS STEEL RIVET STEEL MANDREL		
			CODE NO.	100 PC.	500 PC.	CODE NO.	100 PC.	500 PC.	CODE NO.	100 PC.	500 PC.
3/32"	Up to 1/8	.188	SB3-2	M42100	M40100						
	1/8 to 1/4	.188	SB3-4	M42102	M40102						
1/8"	1/32 to 1/16	.250	SB4-1	M42111	M40111						
	1/16 to 1/8	.250	SB4-2	M42112	M40112	SSB4-2S	M42412	M40412	SSB4-2	M42512	M40512
	1/16 to 1/8	.220	SC4-2	M42113	M40113						
	1/16 to 1/8	.375	SBL4-2	M42114	M40114	SSBL4-2S	M42409	M40409			
	1/8 to 3/16	.250	SB4-3	M42115	M40115	SSB4-3S	M42415	M40415	SSB4-3	M42515	M40515
	1/8 to 3/16	.208							SSBN4-3	M42516	M40516
	1/8 to 3/16	.220	SC4-3	M42116	M40116						
	1/8 to 3/16	.208									
	1/8 to 3/16	.375	SBL4-3	M42124	M40124	SSBL4-3S	M42416	M40416			
	3/16 to 1/4	.250	SB4-4	M42117	M40117	SSB4-4S	M42417	M40417	SSB4-4	M42517	M40517
	3/16 to 1/4	.220	SC4-4	M42118	M40118						
	3/16 to 1/4	.375	SBL4-4	M42119	M40119						
	3/16 to 1/4	.208									
	1/4 to 5/16	.250	SB4-5	M42120	M40120	SSB4-5S	M42420	M40420			
5/16 to 3/8	.250	SB4-6	M42121	M40121	SSB4-6S	M42421	M40421	SSB4-6	M42521	M40521	
3/8 to 1/2	.250	SB4-8	M42122	M40122	SSB4-8S	M42422	M40422	SSB4-8	M42522	M40522	
1/2 to 5/8	.250	SB4-10	M42125	M40125							
5/32"	1/16 to 1/8	.312	SB5-2	M42132	M40132	SSB5-2S	M42432	M40432	SSB5-2	M42532	M40532
	1/8 to 3/16	.312	SB5-3	M42134	M40134						
	3/16 to 1/4	.312	SB5-4	M42135	M40135	SSB5-4S	M42435	M40435	SSB5-4	M42535	M40535
	1/4 to 3/8	.312	SB5-6	M42136	M40136	SSB5-6S	M42436	M40436			
	1/4 to 3/8	.468									
	3/8 to 1/2	.312	SB5-8	M42137	M40137						
3/16"	1/6 to 1/8	.375	SB6-2	M42145	M40145	SSB6-2S	M42445	M40445	SSB6-2	M42545	M40545
	1/8 to 1/4	.375	SB6-4	M42147	M40147	SSB6-4S	M42447	M40447	SSB6-4	M42547	M40547
	1/8 to 1/4	.350	SC6-4	M42151	M40151	SSC6-4S	M42429	M40429			
	1/8 to 1/4	.625	SBL6-4	M42148	M40148						
	1/4 to 3/8	.375	SB6-6	M42149	M40149	SSB6-6S	M42449	M40449	SSB6-6	M42549	M40549
	1/4 to 3/8	.625	SBL6-6	M42150	M40150						
	3/8 to 1/2	.375	SB6-8	M42152	M40152	SSB6-8S	M42450	M40450	SSB6-8	M42550	M40550
	3/8 to 1/2	.625	SBL6-8	M42153	M40153	SSBL6-8S	M42456	M40456			
	1/2 to 5/8	.375	SB6-10	M42155	M40155						
	1/2 to 5/8	.625	SBL6-10	M42156	M40156						
	5/8 to 3/4	.375	SB6-12	M42159	M40159						
	5/8 to 3/4	.625	SBL6-12	M42160	M40160	SSBL6-12S	M42455	M40455			
3/4 to 1	.375	SB6-16	M42170	M40170							
1/4"	1/16 to 1/4	.500	SB8-4	M42181	M41181*						
	1/4 to 3/8	.500	SB8-6	M42183	M41183*						
	3/8 to 1/2	.500	SB8-8	M42185	M41185*						
	1/2 to 5/8	.500	SB8-10	M42187	M41187*						
	5/8 to 3/4	.500	SB8-12	M42189	M41189*						

\* 250 Pack

### Open-End Rivets

RIVET DIA	GRIP RANGE	HEAD DIA	ALUMINUM RIVET ALUMINUM MANDREL			ALUMINUM RIVET STEEL MANDREL			COPPER RIVET COPPER PLATED STEEL MANDREL		
			CODE NO.	100 PC.	500 PC.	CODE NO.	100 PC.	500 PC.	CODE NO.	100 PC.	500 PC.
3/32"	Up to 1/8	.188	AB3-2A	M42200	M40200	AB32	M42300	M40300			
	1/8 to 1/4	.188	AB3-4A	M42202	M40202	AB3-4	M42302	M40302			
1/8"	1/32 to 1/16	.250	AB4-1A	M42211	M40211	AB4-1	M42311	M40311			
	1/16 to 1/8	.250	AB4-2A	M42212	M40212	AB4-2	M42312	M40312	CD4-2C	M42600	M46600
	1/16 to 1/8	.220	AC4-2A	M42213	M40213	AC4-2	M42313	M40313			
	1/16 to 1/8	.375	ABL4-2A	M42214	M40214	ABL4-2	M42314	M40314			
	1/8 to 3/16	.250	AB4-3A	M42215	M40215	AB4-3	M42315	M40315			
	1/8 to 3/16	.208									
	1/8 to 3/16	.220	AC4-3A	M42216	M40216	AC4-3	M42316	M40316			
	1/8 to 3/16	.208	ABN4-3A	M42261	M40261						
	1/8 to 3/16	.375	ABL4-3A	M42224	M40224	ABL4-3	M42324	M40324			
	3/16 to 1/4	.250	AB4-4A	M42217	M40217	AB4-4	M42317	M40317	CD4-4C	M42602	M46602
	3/16 to 1/4	.220	AC4-4A	M42218	M40218	AC4-4	M42318	M40318			
	3/16 to 1/4	.375	ABL4-4A	M42219	M40219	ABL4-4	M42319	M40319			
	3/16 to 1/4	.208	ABN4-4A	M42262	M40262						
	1/4 to 5/16	.250	AB4-5A	M42220	M40220	AB4-5	M42320	M40320			
	5/16 to 3/8	.250	AB4-6A	M42221	M40221	AB4-6	M42321	M40321			
	3/8 to 1/2	.250	AB4-8A	M42222	M40222	AB4-8	M42322	M40322			
1/2 to 5/8	.250	AB4-10A	M42225	M40225							
5/32"	1/16 to 1/8	.312	AB5-2A	M42232	M40232	AB5-2	M42332	M40332			
	1/8 to 3/16	.312	AB5-3A	M42234	M40234	AB5-3	M42334	M40334			
	3/16 to 1/4	.312	AB5-4A	M42235	M40235	AB5-4	M42335	M40335			
	1/4 to 3/8	.312	AB5-6A	M42236	M40236	AB5-6	M42336	M40336			
	1/4 to 3/8	.468									
3/8 to 1/2	.312	AB5-8A	M42237	M40237	AB5-8	M42337	M40337				
3/16"	1/6 to 1/8	.375	AB6-2A	M42245	M40245	AB6-2	M42345	M40345			
	1/8 to 1/4	.375	AB6-4A	M42247	M40247	AB6-4	M42347	M40347			
	1/8 to 1/4	.350	AC6-4A	M42251	M40251	AC6-4	M42346	M40346			
	1/8 to 1/4	.625	ABL6-4A	M42248	M40248	ABL6-4	M42348	M40348			
	1/4 to 3/8	.375	AB6-6A	M42249	M40249	AB6-6	M42349	M40349			
	1/4 to 3/8	.625	ABL6-6A	M42250	M40250	ABL6-6	M42350	M40350			
	3/8 to 1/2	.375	AB6-8A	M42252	M40252	AB6-8	M42352	M40352			
	3/8 to 1/2	.625	ABL6-8A	M42253	M40253	ABL6-8	M42353	M40353			
	1/2 to 5/8	.375	AB6-10A	M42255	M40255	AB6-10	M42355	M40355			
	1/2 to 5/8	.625	ABL6-10A	M42256	M40256	ABL6-10	M42356	M40356			
	5/8 to 3/4	.375	AB6-12A	M42259	M40259	AB6-12	M42359	M40359			
5/8 to 3/4	.625	ABL6-12A	M42260	M40260	ABL6-12	M42360	M40360				
3/4 to 1	.375	AB6-16A	M42266	M40266	ABL6-16	M42366	M40366				
1/4"	1/16 to 1/4	.500	AB8-4A	M42281	M41281*	AB8-4	M42381	M41381			
	1/4 to 3/8	.500	AB8-6A	M42283	M41283*	AB8-6	M42383	M41383			
	3/8 to 1/2	.500	AB8-8A	M42285	M41285*	AB8-8	M42385	M41385			
	1/2 to 5/8	.500	AB8-10A	M42287	M41287*	AB8-10	M42387	M41387			
	5/8 to 3/4	.500	AB8-12A	M42289	M41289*	AB8-12	M42389	M41389			

\* 250 Pack

# Closed-End & Klik-Lock Structural Rivets



## Features & Benefits

- Moisture-resistant due to tight seal
- Greater shear and tensile strength
- Mandrel is retained 100% of time
- 1/8" to 1/4" diameters

## Materials Available

Aluminum / steel, Aluminum / aluminum, Stainless / stainless

## Closed-End Rivets

RIVET DIA	GRIP RANGE	HEAD DIA	ALUMINUM RIVET ALUMINUM MANDREL			ALUMINUM RIVET STEEL MANDREL		
			CODE NO.	100 PC.	500 PC.	CODE NO.	100 PC.	500 PC.
1/8"	1/32 to 1/16	.236				AB4-1CLD	M43600	M46000
	1/16 to 1/8	.236	AB4-2ACLD	M42601	M46201	AB4-2CLD	M43601	M46001
	1/8 to 3/16	.236				AB4-3CLD	M43602	M46002
	3/16 to 1/4	.236	AB4-4ACLD	M42603	M46203	AB4-4CLD	M43603	M46003
	3/16 to 1/4	.236				AC4-4CLD	M43618	M46018
	1/4 to 5/16	.236				AB4-5CLD	M43604	M46004
5/32"	1/16 to 1/8	.312				AB5-2CLD	M43605	M46005
	1/8 to 3/16	.312				AB5-3CLD	M43606	M46006
	1/8 to 1/4	.312	AB5-4ACLD	M42607	M46207			
	3/16 to 5/16	.312				AB5-5CLD	M43607	M46007
3/16"	1/16 to 1/8	.375	AB6-2ACLD	M42608	M46208	AB6-2CLD	M43608	M46008
	1/8 to 1/4	.375	AB6-4ACLD	M42609	M46209	AB6-4CLD	M43609	M46009
	1/4 to 3/8	.375	AB6-6ACLD	M42610	M46210	AB6-6CLD	M43610	M46010
	3/8 to 1/2	.375				AB6-8CLD	M43611	M46011
1/4"	1/8 to 1/4	.500				AB8-4CLD	M46013	
	1/4 to 3/8	.500				AB8-6CLD	M46014	



## Features & Benefits

- Permanently retained mandrel provides increased and tensile values
- Use in high vibration applications
- Provides weather-resistant joint
- Available in 3/16" and 1/4" diameters

## Materials Available

Steel / steel, Aluminum / aluminum, Stainless / stainless

## Klik-Lock Rivets

RIVET DIA	GRIP RANGE	HEAD DIA	PLATED STEEL RIVET STEEL MANDREL			ALUMINUM RIVET ALUMINUM MANDREL			STAINLESS STEEL RIVET STEEL MANDREL		
			CODE NO.	100 PC.	500 PC.	CODE NO.	100 PC.	500 PC.	CODE NO.	100 PC.	500 PC.
3/16"	.062 to .270	.385	SB6-4KL	M41807	M42807	AB6-4AKL	M41821	M42821	SSB6-4SKL	M41833	M42833
	.214 to .437	.385	SB6-7KL	M41808	M42808	AB6-7AKL	M41822	M42822	SSB6-7SKL	M41834	M42834
1/4"	.080 to .375	.525	SB8-6KL	M42810		AB8-6AKL	M42824		SSB8-6SKL	M42836	
	.350 to .625	.525	SB8-10KL	M42811		AB8-10AKL	M42825				

## Drill Reference

RIVET DIA	DRILL NO.	HOLE SIZE
3/32"	#41	.097" to .100"
	2.5 mm	2.46 mm to 2.54 mm
1/8"	#30	.129" to .133"
	3.3 mm	3.28 mm to 3.38 mm
5/32"	#20	.160" to .164"
	4.1 mm	4.06 mm to 4.16 mm

# Multi-Grip Rivets

## Plated Steel Mandrel IFI Grade 30



Multi-grip rivets provide an effective and economical alternative to other, more costly methods of fastening, because one size handles the grip range capacity of up to three standard open end rivets. Multi-grip rivets can be used in any application requiring open end rivets, while reducing inventory requirements. Use multi-grip rivets as a standard open-end rivet. No special tool is needed.

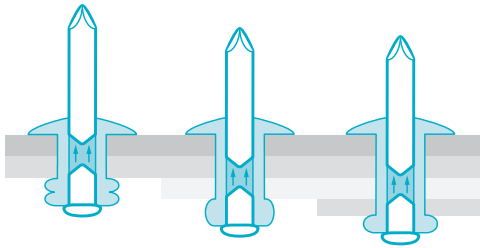

### Features & Benefits

- Extended grip range capacity
- Reduces inventory (fewer sizes required)
- Use as a standard open end rivet
- 1/8" to 3/16" diameters

### Materials Available

Aluminum / steel, Steel / steel

### Steel Buttonhead

HFS PART NO.	BULK PART NO.**	RIVET DIA		DRILL NO. & HOLE		HEAD DIA NOM		HEAD HEIGHT MAX		RIVET LENGTH MAX		GRIP RANGE		TYPICAL ULTIMATE STRENGTH	
		INCH	MM	INCH	MM	INCH	MM	INCH	MM	INCH	MM	INCH	MM	SHEAR	TENSILE
SB41-42MG	M56112	1/8" (.125)	3.2	#30 (.129-.133)	3.3 (3.28-3.38)	.283	7.2	.033	0.85	.355	9.0	.043-.156	1.1-4.0	340lbs (1,510N)	385lbs (1,710N)
SB52-53MG	M56134	5/32" (.156)	4.0	#20 (.160-.164)	4.1 (4.06-4.16)	.319	8.1	.047	1.20	.433	11.0	.056-.196	1.4-5.0	440lbs (1,960N)	530lbs (2,360N)
SB62-63MG	M56146	3/16" (.187)	4.8	#11 (.192-.196)	4.9 (4.88-4.98)	.386	9.8	.069	1.75	.405	10.3	.047-.187	1.2-4.8	810lbs (3,605N)	750lbs (3,335N)
SB63-64MG	M56147	3/16" (.187)	4.8	#11 (.192-.196)	4.9 (4.88-4.98)	.386	9.8	.069	1.75	.500	12.7	.156-.250	4.0-6.3	1,025lbs (4,560N)	780lbs (3,470N)

\*\*Also available in packaged quantities.

### Aluminum / Steel Buttonhead†

AB41-43MG	M56315	1/8"(.125)	#30(.129-.133)	.250	.037	.315	8.0	.031-.187	0.8-4.8	165	230
AB42-44MG	M56317	3.2	3.3(3.28-3.38)	6.35	0.95	.375	9.5	.046-.250	1.2-6.4	735	1025
AB44-45MG	M56320					.438	11.1	.156-.312	4.0-7.9		
AB45-46MG	M56321					.500	12.7	.216-.375	5.5-9.5		
AB52-54MG	M56335	5/32"(.156)	#20(.160-.164)	.312	.047	.375	9.5	.046-.250	1.2-6.4	255	375
AB54-56MG	M56336	4.0	4.1(4.06-4.16)	7.92	1.20	.500	12.7	.156-.375	4.0-9.5	1135	1670
AB56-58MG	M56337					.666	16.9	.250-.500	6.4-12.7		
AB62-64MG	M56347	3/16"(.187)	#11(.192-.196)	.386	.057	.406	10.3	.062-.250	1.6-6.4		
AB63-67MG	M56351	4.8	4.9(4.88-4.98)	9.8	1.45	.595	15.1	.187-.437	4.8-11.1	350	530
SB66-68MG	M56352					.666	16.9	.250-.500	6.4-12.7	1560	2360
AB610-612MG	M56359					.978	24.8	.500-.781	12.7-19.8		

† Mandrel-Zinc with Yellow Dichromate Finish

### Aluminum / Steel Large Flange

ABL42-43MG	M56314	1/8"(.125)	#30(.129-.133)	.325	.039	.315	8.0	.031-.187	0.8-4.8	165	230
ABL42-44MG	M56319	3.2	3.3(3.28-3.38)	8.25	1.00	.375	9.5	.046-.250	1.2-6.4	735	1025
ABL44-45MG	M56322					.438	11.1	.156-.312	4.0-7.9		
ABL52-54MG	M56241	5/32"(.156)	#20(.160-.164)	.374	.051	.375	9.5	.062-.250	1.6-6.4	255	375
ABL53-55MG	M56340	4.0	4.1(4.06-4.16)	9.5	1.30	.438	11.1	.125-.312	3.2-7.9	1135	1670
ABL55-58MG	M56342					.690	17.5	.251-.500	6.4-12.7		
ABL62-64MG	M56350	3/16"(.187)	#11(.192-.196)	.625	.069	.406	10.3	.062-.250	1.6-6.4	350	530
ABL66-68MG	M56353	4.8	4.9(4.88-4.98)	15.85	1.75	.666	16.9	.250-.500	6.4-12.7	1560	2360
ABL610-612MG	M56360					.978	24.8	.500-.781	12.7-19.8		



# Multi-Grip & Special Application Rivets



## Features & Benefits

- Extended grip range capacity
- Reduces inventory (fewer sizes required)
- Use as a standard open end rivet
- 1/8" to 3/16" diameters

## Materials Available

Aluminum / steel, Steel / steel

## Aluminum/Steel 120° Countersunk\*

HFS PART NO.	BULK PART NO.**	RIVET DIA		DRILL NO. & HOLE		HEAD DIA NOM		HEAD HEIGHT MAX		RIVET LENGTH MAX*		GRIP RANGE		TYPICAL ULTIMATE STRENGTH	
		INCH	MM	INCH	MM	INCH	MM	INCH	MM	INCH	MM	INCH	MM	SHEAR	TENSILE
AC43-44MG	M56318	1/8" (.125)	3.2	#30 (.129-.133)	3.3 (3.28-3.38)	.209	5.3	.029	0.75	.383	9.7	.093-.250	2.4-6.4	155lbs (690N)	206lbs (912N)
AC53-55MG	M56357	5/32" (.156)	4.0	#20 (.160-.164)	4.1 (4.06-4.16)	.252	6.40	.049	1.24	.470	11.9	.109-.312	2.7-7.9	255 (1,135N)	300 (1,670N)
AC62-65MG	M56361	3/16" (.187)	4.8	#11 (.192-.196)	4.9 (4.88-4.98)	.345	8.75	.051	1.30	.500	12.7	.062-.312	1.6-7.9	350lbs (1,560N)	530lbs (2,360N)
AC66-68MG	M56362	3/16" (.187)	4.8	#11 (.192-.196)	4.9 (4.88-4.98)	.345	8.75	.051	1.30	.690	17.5	.250-.500	6.4-12.7	350lbs (1,560N)	530lbs (2,360N)

\* Countersunk-Total Length (L) including head. \*\*Also available in packaged quantities.



## Features & Benefits

- Small flange rivet used primarily for fastening decorative materials on boats, automobiles, trucks and other motor vehicles
- Best suited to applications where a discreet, secure installation of non-critical components is needed.

## Materials Available

Stainless / steel, Aluminum / aluminum

## Trim Rivets

500 PACK NO.	DESCRIPTION	GRIP RANGE	MATERIALS BODY / MANDREL	RIVET DIA NOM	FLANGE DIA NOM	HOLE DIA RANGE
M40261	Trim Moulding Rivet	.126-.187	Alum / Alum	.125	.208	.129-.133
M40262	Long Trim Moulding Rivet	.188-.250	Alum / Alum	.125	.208	.129-.133
M40516	Trim Moulding Rivet w/SS Body	.126-.187	SS / Steel	.125	.208	.129-.133

Use 39112 Trim Clip Rivet Nosepieces with HP-2 or Kliker Riveter to form trim clip studs with 50261; 50262; 50516 rivets.

## Klik-Split® Window and Door Rivets†

50 PACK NO.	DESCRIPTION	GRIP RANGE	MATERIALS BODY / MANDREL	RIVET DIA NOM	FLANGE DIA NOM	HOLE DIA RANGE	BULK PACK NO.	APPLICATIONS
M42371	Window Regulator Rivet	.032-.140	Alum / Steel	.250	.500	.257-.261	M52371	GM 9436175
								Ford 385189
								Chry 6031115
M42372	Outside Door Handle Rivet with recessed head	.090-.115	Alum / Steel	.250	.500	.257-.261	M52372	Ford 388047-5100
M42373	Door Handle Rivet w/recessed head and zinc coated mandrel	.110-.177	Alum / Steel	.250	.500	.257-.261	M52373	GM 20713843
M42374	Window Regulator Rivet w/yellow zinc coated mandrel	.140-.187	Alum / Steel	.250	.500	.257-.261	M52374	GM 9437486
								Chry 6032926
M42375	Black. Anodized Door Handle Rivet	.090-.115	Alum / Steel	.250	.500	.257-.261	M52375	Ford 388047-5102
M42376	Glass Stop Rivet	.520-.620	Alum / Steel	.250	.500	.257-.261	M50376	Ford 385323
								Chry 6031091

† Requires nosepiece No. 96028 when using the Marson brand Big Daddy (39031) hand tool.

# Special Application Rivets & Backup Washers



## Features & Benefits

- Small flange rivet used primarily for fastening decorative materials on boats, automobiles, trucks and other motor vehicles
- Best suited to applications where a discreet, secure installation of non-critical components is needed

## Materials Available

Stainless / steel, Aluminum / Steel,  
Aluminum / aluminum

## Bumper Rivets

50 PACK NO.	DESCRIPTION	GRIP RANGE	MATERIALS BODY / MANDREL	RIVET DIA NOM	FLANGE DIA NOM	HOLE DIA RANGE	APPLICATIONS
M43150	Bumper Fascia Rivet large flange black	.250-.375	Steel / Steel	.187	.625	.192-.196	GM 9439719
M43181	Bumper Fascia Rivet w/yellow zinc coated mandrel	.125-.250	Steel / Steel	.250	.500	.257-.261	Ford 372820-S36

## Misc. Rivets

50 PACK NO.	DESCRIPTION	GRIP RANGE	MATERIALS BODY / MANDREL	RIVET DIA NOM	FLANGE DIA NOM	HOLE DIA RANGE	APPLICATIONS
M43295	Rear Window Gasket Rivet	.125-.187	Alum / Steel	.125	.325	.129-.130	GM 20325696
M43314	Multi-Purpose Rivet, large flange	.125-.187	Alum / Steel	.125	.375	.129-.130	GM 9432552
M43353	Trunk Lock Swivel Emblem Rivet sealed end, countersunk head Requires Nosepiece #39144	.126-.187	Alum / Steel	.156	.312	.160-.164	GM 9432137 Chry 6032138

## Backup Washers

PART NO.	CODE NUMBER	NOMINAL HOLE SIZE	PACK SIZE	MATERIAL	ACTUAL HOLE SIZE	SIZE / SHAPE
M40656	SS-6	3/16"	500	Steel	0.192	1/2"-Square
M40657	AS-8	1/8"	500	Aluminum	0.13	3/8"-Round
M40658	SS-8	1/8"	500	Steel	0.13	3/8"-Round
M40660	AS-10	3/16"	500	Aluminum	0.192	1/2"-Round
M40661	SS-10	3/16"	500	Steel	0.192	1/2"-Round
M86658	SS-8	1/8"	100	Steel	0.13	3/8"-Round
M86657	AS-8	1/8"	100	Steel	0.13	3/8"-Round
M86660	AS-10	3/16"	100	Aluminum	0.192	1/2"-Round
M86661	SS-10	3/16"	100	Steel	0.192	1/2"-Round

# Klik-Lok™ Plastic Rivets

Marson brand Klik-Lok™ Plastic Rivets are the same precision-molded all-nylon rivets used by domestic auto manufacturers, both for original equipment and replacement parts. In addition, Klik-Lok Plastic Rivets are ideal for non-conductive and non-corrosive environments. Klik-Lok Plastic Rivets fasten plastic to plastic, plastic to metal and plastic to fiberglass. As they set, three “legs” form to securely lock the components in place and prevent pullout.



## Features & Benefits

- Precision-molded, all-nylon
- Secure lock prevents pull-out
- Fasten plastic to plastic, plastic to metal or plastic to fiberglass

## Klik-Lok™ Plastic Rivets

DIAGRAM REFERENCE	100-PACK PART NO.*	D	HOLE SIZE		H	E	L	GRIP RANGE INCH	TYPICAL ULTIMATE STRENGTH (LBS.)	
		RIVET DIA NOM INCH	INCH	(MM)	HEAD DIA NOM INCH	HEAD HEIGHT MAX INCH	RIVET LENGTH MAX INCH		SHEAR	TENSILE
A	M48286	.154	.156	(4)	.315	.098	1.024	.236 - .413	40	82
B	M48305	.195	.197	(5)	.472	.130	.728	.059 - .177	68	120
C	M48306	.195	.197	(5)	.472	.071	.787	.118 - .236	68	120
D	M48307	.195	.197	(5)	.472	.071	.787	.118 - .177	68	120
E	M48308	.195	.197	(5)	.472	.071	.984	.236 - .394	68	120
F	M48309	.195	.197	(5)	.354	.071	.650	.118 - .157	68	120
G	M48330	.234	.236	(6.0)	.512	.098	1.102	.157 - .335	110	181
H	M48349	246	.250	(6.3)	.669	.098	.709	.157 - .236	121	194
I	M48350	246	.250	(6.3)	.669	.098	1.102	.157 - .394	121	194
J	M48351	246	.250	(6.3)	.512	.098	1.102	.157 - .394	121	194
K	M48353	246	.250	(6.3)	.670	.098	.682	.028 - .193	121	194
L	M48354	246	.250	(6.3)	.670	.098	.682	.028 - .178	121	194
M	M48385	.258	.260	(6.6)	.512	.098	.787	.098 - .197	137	219
N	M48386	.258	.260	(6.6)	.709	.098	.787	.098 - .197	137	219

\* Also available in bulk 2,000/ctn and visual boxes, 20/pkg.

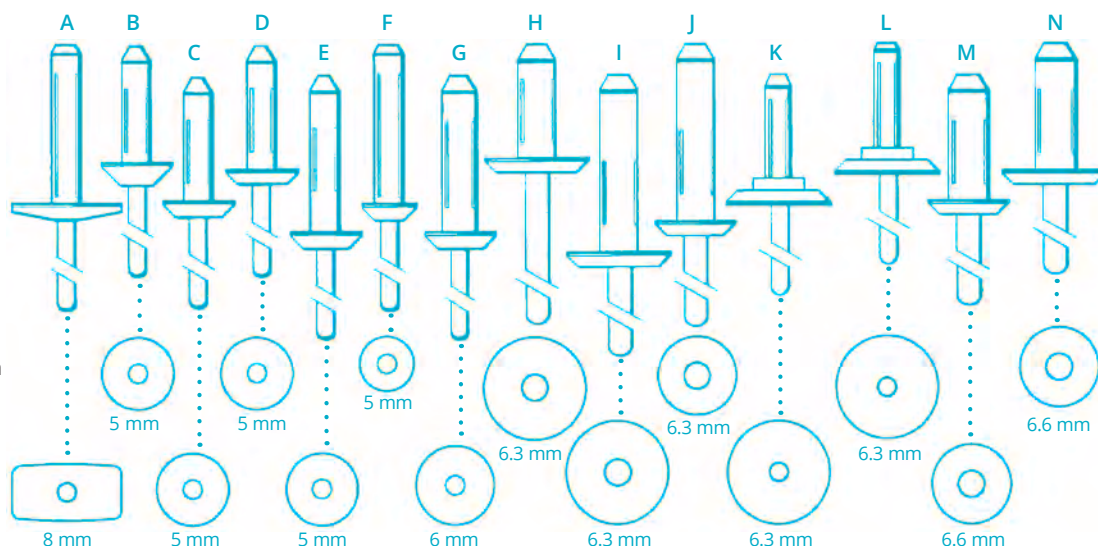

### Actual Size Rivets/Flanges

When ordering, match diagram reference letter with those in the chart.

# Rivet Nuts & Tools

More sizes. More finishes. More Howmet quality. That's what you'll get with Marson Rivet Nuts. This industry standard Rivet Nut line features a wide range of types, sizes and finishes including ribbed, hex body, neoprene / brass and knurled designs, all manufactured for reliability and strength. All while delivering the superior features and benefits you've come to expect from Howmet Fastening Systems. In addition, the Rivet Nut system includes a broad selection of tools providing ease of installation.

## SST Series

The versatile, low cost Spin/Spin pneumatic Rivet Nut production tool now comes with a quick-change nosepiece assembly and standard socket head cap screw for convenient replacement and change-over. For added ease of operation, the Spin/Spin offers a superior ergonomic design, lightweight body and operates without stroke adjustment. Available models come with two front assemblies of your choice (refer to table below).

MARSON SPIN / TOOL MODEL	3000 RPM / SST-1	1500 RPM / SST-2		600 RPM / SST-3		400 RPM / SST-4
THREAD SIZE	RECOMMENDED	RECOMMENDED	OPTIONAL	RECOMMENDED	OPTIONAL	RECOMMENDED
4-40	✓					
6-32	✓					
8-32	✓		✓			
10-24		✓			✓	
10-32		✓			✓	
1/4-20			✓	✓		
1/4-28			✓	✓		
5/16-18					✓	✓
5/16-24					✓	✓
3/8-16						✓
3/8-24						✓
M3	✓					
M4	✓		✓			
M5		✓			✓	
M6			✓	✓		
M8					✓	✓
M10						✓

### OPERATOR IS LIABLE FOR CORRECT AIR PRESSURE. DO NOT EXCEED 100 PSI.

Purchasing the Optional Front End Assemblies are at the Owner's discretion. Care must be taken to optimize the tool's Rivet Nut setting ability. Recommended for thin wall Rivet Nuts only. Adjustment of the air pressure will be necessary in order for the tool to function in both minimum and maximum capacity on ALL optional thread sizes per tool. Contact customer service for available retrofit for MET external thread.

### Additional nosepiece and mandrel sizes are available:

SST-1/M39801 - 3000 RPM  
 SST-2/M39802 - 1500 RPM  
 SST-3/M39803 - 600 RPM  
 SST-4/M39804 - 400 RPM





# Marson® BT-8

The Marson® BT-8 is a battery-powered rivet-nut installation tool designed to deliver reliable pull-force for high volume assembly applications. Engineered for versatility and extensive use on factory floors and job sites, this portable powerhouse offers an exceptional value. The BT-8 Battery Riveter Kit E8000 includes battery charger in a convenient carry case.



**Capacity:** Mandrel Thread Size

Metric: M4, M5, M6, M8, M10, M12

Inch: 8-32, 10-24, 10-32, 1/4 - 20, 5/16 - 18, 3/8 - 16

**Stroke Length:** 6 mm

**Pulling Force:** 3,579 lbf

**Weight (with Li-ion battery pack):** 2.15kg/5 lbs

**Battery Pack:** 18 V/ Li-ion / 2Ah

**Recharge Time:** Approximately 45 minutes

## Drill-Out Kits

PART NO.	DESCRIPTION	NOTES
M38997	BT-8 Battery Riveter Kit E8000	
M38992	Extra Battery	BT5/6/8 18V/2Ah Li-Ion battery
M38993	High-Capacity Battery	T5/BT6 20V/4Ah Li-Ion battery
M38995	Extra Charger	BT5/6/8 Charger - UL/CE Plug

# Rivet Nut Tools

## Klik-Turn® SRN-2 / M39400

The SRN-2 swivel head, hand held Rivet Nut tool features a positive-ratchet locking feature which allows the swivel head to turn 360°. This feature helps hold in place in forty-plus positions. An innovative design, the SRN-2 features a heavy-duty steel plate upper handle and precision die-cast body of high-strength aluminum. In addition, the SRN-2 offers adjustable stroke with a positive locking feature, quick-change mandrel, comfortable hand grips and longer handles to improve leverage. Included are built-in threaded nosepiece storage holes and a service wrench. The SRN-2 can set steel and aluminum Rivet Nuts up to 1/4-20" and 6 mm. The tool is supplied with 6-32, 8-32, 10-24, 10-32 and 1/4-20 mandrels and nosepieces.

### Mandrel / Nosepiece

THREAD SIZE	MANDREL NO.	NOSEPIECE NO.
6-32	M39454	M39361
8-32	M39455	M39362
10-24	M39456	M39363
10-32	M39457	M39363
1/4-20	M39458	M39379
1/4-28*	M39471	M39379
4 mm*	M39466	M39374
5 mm*	M39467	M39373
6 mm*	M39468	M39375

\*Sold separately

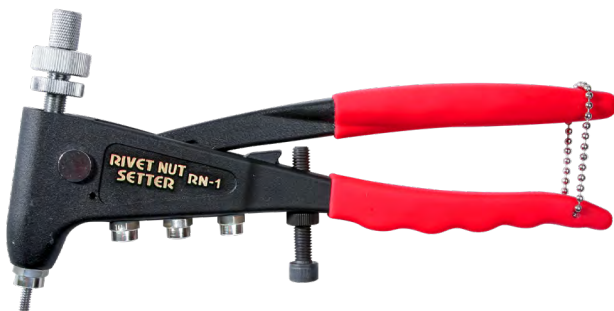

## Rivet Nut Setter RN-1 / M39300

The RN-1 features a quick-change mandrel, long handles for improved leverage, and a locking adjustable-stroke. Ergonomically designed with a forged, heat-treated steel upper handle, precision die-cast body of high-strength aluminum alloy, patented fulcrum pin design and comfortable hand grips. This tool includes 8-32, 10-24 and 10-32 mandrels and nosepieces, but can install all sizes of Rivet Nuts and threaded inserts up to 1/4-20 and 6 mm threads in steel with optional mandrels and nosepieces. Available in a variety of other kits.

Weight: 1.2 lbs.



## 325RN / M34604

Choose the M34604 for installing larger size Rivet Nuts. Model M34604 is a heavy-duty tool that will install 10-24 through 3/8"-16, and 5 mm through 10 mm threaded inserts in aluminum or steel. It features quick-change mandrels with an easily adjustable stroke. Supplied with 1/4"-20 mandrel and nosepiece only.

Weight: 4.25 lbs.

# Rivet Nut Kits

## Rivet Nut Kit / M39301

Model M39301 Rivet Nut Kit contains the M39300 Rivet Nut tool in a molded plastic case; mandrels and nosepieces for 6-32, 8-32, 10-24 and 1/4-20, instructions and wrench. The kit also includes 103 assorted Klik Rivet Nuts and Klik Poly-Nuts: 25 each M57210, M57425, M57130; 20 each M57250; 8 each M57445.

Weight: 2.75 lbs.

## Poly-Nut Kit / M39302

Model M39302 Poly-Nut Kit contains the M39300 Rivet Nut tool in a molded plastic case with 8-32, 10-32 and 1/4-20 mandrels and nosepieces, wrench and instructions. The kit contains 52 assorted Klik Poly-Nuts: 12 each M57425, M57435, M57445; 16 each M57455.

Weight: 3 lbs.

## Metric Poly-Nut Kit / M39303

Model M39303 Metric Poly-Nut Kit contains the M39300 Rivet Nut tool in a molded plastic case with 4 mm, 5 mm, 6 mm and 8 mm mandrels and nosepieces, wrench and instructions. The kit contains 75 assorted Klik Poly-Nuts: 25 each M57407, M57409; 15 each M57411; 10 each M57413.

Weight: 3.25 lbs.

## Aluminum Klik Thread-Sert Kit / M39313

Model M39313 Thread-Sert Kit contains the M39300 Rivet Nut tool in a molded plastic case with 6-32, 8-32, 10-24, 10-32, 1/4-20, 5/16-18 and 3/8-16 mandrels and nosepieces, wrench and instructions. The kit contains 62 assorted Aluminum Klik Thread-Serts: 10 each M57910, M57920, M57930, M57940, M57950; 6 each M57971, M57981.

Weight: 3 lbs.

## Steel Klik Thread-Sert Kit / M39314

Model M39314 Thread-Sert Kit contains the M39300 Rivet Nut tool in a plastic case with 6-32, 8-32, 10-24, 10-32, 1/4-20, 5/16-18 and 3/8-16 mandrels and nosepieces, wrench and instructions. The kit contains 62 assorted Steel Klik Thread-Serts: 10 each M57810, M57820, M57830, M57840, M57850; 6 each M57871, M57881.

Weight: 3.25 lbs.

## Ribbed Rivet Nut Kit / M39315

Model M39315 Ribbed Rivet Nut kit contains the M39300 Rivet Nut tool in a molded plastic case; mandrels, nosepieces, wrench and instructions for setting 8-32, 10-24, 10-32 and 1/4-20 Rivet Nuts. The kit also includes 50 assorted Ribbed style Rivet Nuts: 12 each M57320, M57330, M57340; 8 each M57350; 6 each M57354.

Weight: 2.75 lbs.

## Metric Ribbed Rivet Nut Kit / M39316

Model M39316 Ribbed Rivet Nut kit contains the M39300 Rivet Nut tool in a molded plastic case with 4 mm, 5 mm and 6 mm mandrels and nosepieces, wrench and instructions. The kit also includes 50 assorted Ribbed style Rivet Nuts: 12 each M57360, M57385, M57384; 8 each M57386; 6 each M57387.

Weight: 2.75 lbs.



# ML Series Ribbed Rivet Nuts

## Available in Steel-Zinc Plated or Aluminum Class 2B Threads

ML Series Ribbed Rivet Nuts provide an efficient and cost-effective method of placing permanent threads in thin materials. Installed from one side, these inserts are perfect for use in metal, fiberglass and rigid plastic too thin for tapped threads. Lightweight manual and pneumatic tooling ensures easy installation. Once in place, the insert's internal threads are ready for a screw or bolt. Additional features include: increased torque strength over conventional style, 60° ribbed expansion after setting, vibration resistance and a large flanged head which increases push out strength.

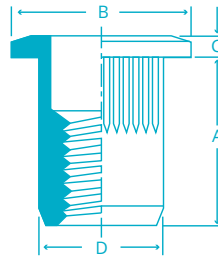

## ML Series Rivet Nut Specifications

THREAD SIZE	STEEL BULK PART #	ALUMINUM BULK PART #	A BODY LENGTH +/- .015"	B HEAD DIA +/- .010"	C HEAD HEIGHT +/- .003	D BODY DIA	GRIP RANGE		HOLE SIZE +.006 - .004
							MIN	MAX	
6-32	M47310	M47610	.42	.39	.03	.265	.020	.080	17/64
	M47312	M47612	.47				.080	.130	
8-32	M47320	M47620	.42	.39	.03	.265	.020	.080	17/64
	M47321	M47621	.47				.080	.130	
10-24	M47330	M47630	0.475	.415	.03	.296	.020	.130	19/64
	M47332	M47632	.585				.130	.225	
10-32	M47340	M47640	0.475	.415	.03	.296	.020	.130	19/64
	M47342	M47642	.585				.130	.225	
1/4-20	M47350	M47650	.58	.5	.03	.39	.027	.165	25/64
	M47354	M47654	.68				.165	.260	
1/4-28	M47358	M47658	.58	.5	.03	.39	.027	.165	25/64
	M47359	M47659	.68				.165	.260	
5/16-18	M47371	M47671	.69	.685	.035	.53	.027	.150	17/32
	M47374	M47674	.805				.150	.312	
5/16-24	M47378	M47678	.69	.685	.035	.53	.027	.150	17/32
	M47379	M47679	.805				.150	.312	
3/8-16	M47381	M47681	.69	.865	.035	.53	.027	.150	11/16
	M47382	M47682	.805				.150	.312	
3/8-24	M47395	M47695	.69	.685	.035	.53	.027	.150	11/16
	M47396	M47696	.805				.150	.312	
M4x.07	M47360	M47660	10.67	9.91	.76	6.73	.05	2.0	6.75
	M47365	M47665	11.94				2.0	3.3	
M5x0.8	M47385	M47684	12.07	10.54	.76	7.52	.05	3.3	.76
	M47384	M47685	14.86				3.3	5.7	
M6x1.0	M47386	M47686	14.73	12.7	.76	9.91	.07	4.2	10
	M47387	M47687	17.27				4.2	6.6	
M8x1.25	M47388	M47688	17.53	17.4	.89	13.46	.07	3.8	13.5
	M47389	M47689	20.45				3.8	7.9	
M10x1.5	M47390	M47690	17.53	17.4	.89	13.46	.07	3.8	13.5
	M47391	M47691	20.45				3.8	7.9	



# MRN Series Flathead Rivet Nuts

## Available in Steel-Zinc Plated or Aluminum Class 2B Threads

Lightweight tooling ensures easy installation by the operator and reduces costs when compared with other methods. After installation, MRN Series Rivet Nuts provide permanent, captive threads that do not allow loosening under vibration and will not rotate when attached to the mating material.

MRN Series Rivet Nuts can be used in a wide range of applications and are designed to provide a very efficient and cost-effective method of placing permanent threads in thin materials. Installed from one side, MRN Nuts are perfect for use in metal, fiberglass and rigid plastic previously too thin for tapped threads. They provide a neat appearance and, once in place, the internal threads are ready for a screw or bolt.

MRN Series Rivet Nuts with large diameter heads can be used in soft materials which inherently offer little, if any, thread strength.

The flathead design provides the most bearing surface for higher torque applications. The larger flange extends above the material in which it is installed and provides a built-in spacer.

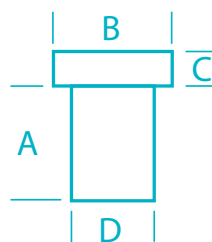

## MRN Series Flathead Rivet Nut Specifications (Inch)

THREAD SIZE	STEEL BULK PART NO.	ALUMI-NUM BULK PART NO.	A BODY LENGTH $\pm .015"$	B HEAD DIA REF $\pm .015$	C HEAD HEIGHT (NOM)	D BODY DIA MAX $\pm .000$ -.004	GRIP RANGE		HOLE SIZE		DRILL SIZE
							MIN	MAX	MIN	MAX	
6-32	M47110	M47210	.438	.325	.032	.189	.010	.075	.189	.193	# 12
8-32	M47120	M47220	.438	.357	.032	.221	.010	.075	.221	.226	# 2
	M47121	M47221	.500				.075	.120	.221	.226	
10-24	M47130	M47230	.531	.406	.038	.250	.010	.080	.250	.254	1/4"
	M47132	M47232	.594				.080	.130	.250	.254	
10-32	M47140	M47240	.531	.406	.038	.250	.010	.080	.250	.254	1/4"
	M47142	M47242	.594				.080	.130	.250	.254	
1/4-20	M47150	M47250	.625	.475	.058	.332	.020	.080	.332	.338	Q
	M47152	M47252	.687				.080	.140	.332	.338	
	M47154	M47254	.750				.140	.200	.332	.338	
5/16-18	M47171	M47271	.750	.665	.062	.413	.030	.125	.413	.423	Z
	M47174	M47274	.875				.125	.200	.413	.423	
3/8-16	M47181	M47281	.844	.781	.088	.490	.030	.115	.490	.500	1/2"
	M47184	M47284	.938				.115	.200	.490	.500	

# Poly-Nuts & MQN Series Quad Leg Nuts

## Available in Steel-Zinc Plated or Aluminum Class 2B Threads

Poly-Nuts can be used in a wide range of applications and are designed to provide a very efficient and cost-effective method of placing permanent threads in thin materials. Installed from one side, Poly-Nuts are perfect for use in metal, fiberglass and rigid plastic previously too thin for tapped threads. Poly-Nuts provide a nearly flush appearance and, once in place, the internal threads are ready for a screw or bolt. Lightweight tooling ensures easy installation by the operator and reduces costs when compared with other methods. After installation, Poly-Nuts provide permanent, captive threads that do not allow loosening under vibration and will not rotate when attached to the mating material.

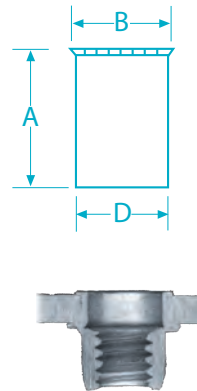

## Poly-Nut (Expander) Specifications

THREAD SIZE	STEEL BULK PART #	ALUMINUM BULK PART #	A BODY LENGTH +/- .015"	B HEAD DIA REF +/- .015	D BODY DIA +/- .005	GRIP RANGE		HOLE SIZE*		DRILL SIZE
						MIN	MAX	MIN	MAX	
6-32	M47415	M47510	.410	.287	.249	.020	.080	.250	.254	1/4"
8-32	M47425	M47520	.410	.287	.249	.020	.080	.250	.254	1/4"
10-24	M47435	M47530	.465	.320	.280	.020	.130	.281	.285	9/32"
10-32	M47445	M47540	.465	.320	.280	.020	.130	.281	.285	9/32"
1/4-20	M47455	M47550	.610	.415	.374	.030	.165	.375	.379	3/8"
5/16-18	M47475	M47575	.720	.540	.499	.030	.165	.500	.504	1/2"
3/8-16	M47485	M47585	.720	.540	.499	.030	.165	.500	.504	1/2"
4 mm	M47407	-	.410	.287	.249	.020	.080	.250	.254	1/4"
5 mm	M47409	-	.465	.320	.280	.020	.130	.281	.285	9/32"
6 mm	M47411	-	.610	.415	.374	.030	.165	.375	.379	3/8"
8 mm	M47413	-	.720	.540	.499	.030	.165	.500	.504	1/2"
10 mm	M47414	-	.720	.540	.499	.030	.165	.500	.504	1/2"

\* Note: Hole size is critical for proper installation

## Quad Leg Nut Installation Tool (MJN-2 / M39043)

Marson's MJN-2 hand-held Quad Leg Nut Installation tool is designed to effortlessly set quad leg nuts and Jack Nuts® in sizes ranging from #6-32 to 1/4-20 and M4 to M6. It works by threading the bolt to the quad leg nut, then dropping the component in the slot of the tool, inserting it into the pre-drilled hole and squeezing until set. Tightening the exposed bolt completes the installation.

Jack Nut® is a registered trademark of Stanley Engineered Fastening.



## MQN Series Quad-Leg Rivet Nut

THREAD SIZE	GRIP RANGE MIN-MAX	STEEL BULK PART NO*	A OVERALL LENGTH	B HEAD DIA REF	E HEAD HIEGHT (NOM)	D BODY DIA MAX	HOLE SIZE MIN-MAX	DRILL SIZE
6-32	.000 - .197	M52510	.670	.472	.063	.315	.318 - .330	P (.323)
6-32	.197 - .394	M52511	.866	.472	.063	.315	.318 - .330	P (.323)
10-24	.000 - .197	M52530	.709	.547	.063	.394	.397 - .406	X (.397)
10-24	.197 - .394	M52532	.906	.547	.063	.394	.397 - .406	X (.397)
1/4-20	.000 - .197	M52550	.709	.630	.063	.472	.475 - .487	31/64
1/4-20	.197 - .394	M52554	.906	.630	.063	.472	.475 - .487	31/64
M4x0.7	.0 - 5.0	M52560	17.0	12.0	1.60	8.0	8.08 - 8.38	P (.323)
M4x0.7	5.0 - 10.0	M52565	22.0	12.0	1.60	8.0	8.08 - 8.38	P (.323)
M5x0.8	.0 - 5.0	M52584	18.0	13.9	1.60	10.0	10.08 - 10.31	X (.397)
M5x0.8	5.0 - 10.0	M52585	23.0	13.9	1.60	10.0	10.08 - 10.31	X (.397)
M6x1.0	.0 - 5.0	M52586	18.0	16.0	1.60	12.0	12.06 - 12.37	31/64
M6x1.0	.0 - 5.0	M52587	23.0	16.0	1.60	12.0	11.13 - 11.43	31/64

\*Also available in small packaged quantities. Inch sizes are class 2B thread. Metric sizes are class 6H thread.

# MNN — Neoprene Inserts

Neoprene Insert contains pre-molded brass nut for quick fastening in vibration, moisture protection, shock dampening and even electrical insulation applications. Easy installation is possible from blind side with conventional wrench. Just insert the proper thread screw or bolt and tighten.

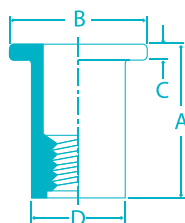

## MNN Series Neoprene Insert

THREAD SIZE	GRIP RANGE MIN-MAX	BULK PART NO.	A BODY LENGTH ±.015" ± 0.38 MM	B HEAD DIA ±.010" ± 0.254 MM	C HEAD HEIGHT ±.003" ± 0.76 MM	D BODY DIA MAX	HOLE SIZE MIN-MAX	DRILL SIZE MIN-MAX
6-32	.015-.157	M52710	.496	.433	.055	.312	.312 - .323	5/16
8-32	.015-.157	M52720	.496	.433	.055	.312	.312 - .323	5/16
10-32	.015-.193	M52730	.555	.500	.035	.378	.378 - .386	W (.386)
10-32	.033-.232	M52731	.669	.551	.039	.378	.378 - .386	W (.386)
10-32	.031-.228	M52732	.709	.748	.079	.378	.378 - .386	W (.386)
10-32	.031-.228	M52733	.825	.746	.185	.378	.378 - .386	W (.386)
10-32	.311-.630	M52734	.846	.551	.035	.378	.378 - .386	W (.386)
10-32	.311-.449	M52735	1.030	.551	.051	.378	.378 - .386	W (.386)
10-32	.984-1.256	M52736	1.732	.551	.035	.378	.378 - .386	W (.386)
1/4-20	.015-.110	M52750	.630	.630	.051	.500	.500 - .508	1/2
1/4-20	.031-.185	M52751	.831	.750	.187	.500	.500 - .508	1/2
1/4-20	.252-.453	M52752	1.051	.642	.079	.500	.500 - .508	1/2
1/4-20	.453-.906	M52753	1.377	.630	.051	.512	.512 - .520	33/64
5/16-18	.015-.157	M52771	.720	.847	.126	.626	.626 - .634	41/64
5/16-18	.156-.374	M52772	1.099	.847	.225	.626	.626 - .634	41/64
5/16-18	.079-.709	M52773	1.970	.787	.063	.750	.750 - .758	3/4
3/8-16	.748-1.570	M52781	2.165	.886	.051	.750	.750 - .758	3/4
1/2-13*	1.470-1.575	M52791	3.070	1.060	.051	.945	.945 - .953	61/64
M3-0.5	.4-4.0	M52810	12.6	11.0	1.4	7.9	7.90 - 8.20	7.9
M4-0.7	.4-4.0	M52820	12.6	11.0	1.4	7.9	7.90 - 8.20	7.9
M5-0.8	.4-4.9	M52830	14.1	12.7	.9	9.6	9.60 - 9.80	9.6
M5-0.8	.85-5.9	M52831	17.0	14.0	1.0	9.6	9.60 - 9.80	9.6
M5-0.8	.8-5.8	M52832	18.0	19.0	2.0	9.6	9.60 - 9.80	9.6
M5-0.8	.8-5.8	M52833	20.95	18.95	4.7	9.6	9.60 - 9.80	9.6
M5-0.8	7.9-16	M52834	26.1	14.0	1.3	9.6	9.60 - 9.80	9.6
M5-0.8	7.9-11.4	M52835	21.5	14.0	.9	9.6	9.60 - 9.80	9.6
M5-0.8	20.5-30	M52836	39.8	14.0	1.3	9.6	9.60 - 9.80	9.6
M6-1.0	.4-2.8	M52850	16.0	16.0	1.3	12.7	12.7 - 12.9	1/2
M6-1.0	.8-4.7	M52851	21.1	19.05	4.75	12.7	12.7 - 12.9	1/2
M6-1.0	6.4-11.5	M52852	26.7	16.3	2.0	12.7	12.7 - 12.9	1/2
M6-1.0	11.5-23	M52853	35.0	16.0	1.3	13.0	13.0 - 13.20	13.0
M8-1.25	.4-4.0	M52871	18.3	21.5	3.2	15.9	15.9 - 16.1	16.0
M8-1.25	3.95-9.5	M52872	27.93	21.5	5.72	15.9	15.9 - 16.1	16.0
M8-1.25	2.0-18.0	M52873	50.0	20.0	1.6	18.0	18.0 - 18.2	18.0
M10-1.5	19.0-40.0	M52881	55.0	22.5	1.3	15.9	20.0 - 20.2	20.0
M12-1.75	36.0-64.0	M52891	78.0	27.0	1.3	15.9	24.0 - 24.2	24.0

Metric sizes are class 6H thread. \* Built to order, minimums required.

# Huck® Tools and Fasteners

When you see the Huck® name, you know it'll stay fastened tight, no matter how vibration-intensive the application. It's this superior holding strength that has built Huck's reputation as one of the leading suppliers of engineered fastening systems for both OEM and aftermarket applications.

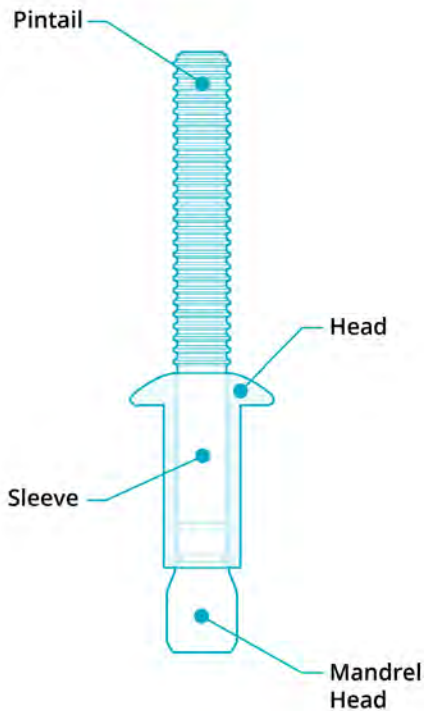

You'll find Huck fasteners in a number of critical areas of trucks and trailers. In truck chassis, swaged HuckBolts ensure the long-term joint integrity of shock mounts, suspension members, ladder assemblies and 5th wheel angles. Additionally, they never require inspection, re-tightening or re-torquing.

## How Structural Blind Fasteners Work

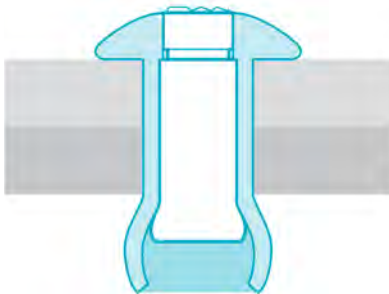

### TENSILE STRENGTH

Huck Structural Blind Rivets form a blind side positive lock either by bulbing or expanding of the sleeve. The sleeve, assisted by the permanently secured bolt, therefore resists failure along its center line.

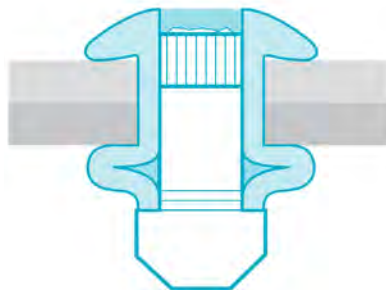

### BULBING

The sleeve of the fastener is compressed, causing it to fold outwards to form a bulb. This form itself tightly against the joint material. Once the bolt is permanently locked into place the pintail will break off, completing the installation.

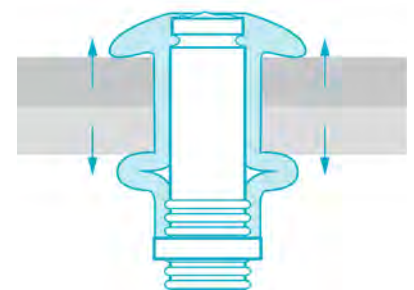

### EXPANDING

Pulling on the pintail causes the head of the bolt to draw into the sleeve. This expansion causes a foot print to form against the joint material.





## Huck HK-150

The Huck HK-150 is an easy-to-use, lightweight (18 oz.) riveter. Ideal for repair and maintenance applications, the manually operated, hydraulically powered HK-150 can efficiently install rivets from 3/32" through 1/4".

HFS offers a wide range of pull-up studs and anvils, both metric and imperial. For more information please consult the price list.

### HK Studs for Rivet Nut Installation

PART NO.	DESCRIPTION
205467	Pull-Up Stud / Anvil 3 mm
205484	Pull-Up Stud / Anvil 4 mm
205469	Pull-Up Stud / Anvil 5 mm
205485	Pull-Up Stud / Anvil 6 mm
205486	Pull-Up Stud / Anvil 8 mm
205488	Pull-Up Stud / Anvil 10 mm
205471	Pull-Up Stud / Anvil 10-24
205472	Pull-Up Stud / Anvil 1/4-20
205473	Pull-Up Stud / Anvil 6-32
205474	Pull-Up Stud / Anvil 8-32
205475	Pull-Up Stud / Anvil 10-32
205476	Pull-Up Stud / Anvil 1/4-28
205477	Pull-Up Stud / Anvil 4-40
205487	Pull-Up Stud / Anvil 3/8-16
205489	Pull-Up Stud / Anvil 5/16-18
205456	Pull-Up Stud / Anvil 10-24
205457	Pull-Up Stud / Anvil 1/4-20
205458	Pull-Up Stud / Anvil 5/16-18
205459	Pull-Up Stud / Anvil 3/8-16
205460	Pull-Up Stud / Anvil 6-32
205461	Pull-Up Stud / Anvil 8-32
205462	Pull-Up Stud / Anvil 10-32
205463	Pull-Up Stud / Anvil 1/4-28
205464	Pull-Up Stud / Anvil 4-40
205465	Pull-Up Stud / Anvil 5/16-24
205466	Pull-Up Stud / Anvil 3/8-24



## Huck AK-175

Built for maintenance and repair applications in the shop or in the field, the Huck AK-175 riveter is compact and lightweight at only 26 oz. Despite its light weight, it develops 3,500 pounds of pulling force. Highly versatile, the AK-175 features a unique jaw system allowing setting of rivets from 1/8" through 1/4" using changeable nosepieces.



## Huck 205400

Designed to crimp U.S. and imperial Rivet Nuts into thin metal sheeting, the 205400 includes master shaft assembly and turn nut, 1/4-20 and 10-24 pull-up studs and driving anvils.



## Huck 205401

This comprehensive kit crimps metric Rivet Nuts into thin metal sheeting. It includes master shaft assembly and turn nut, as well as 6 mm and 8 mm pull-up studs and driving anvils.

# Huck Tools and Kits

## Huck Range Force

The Huck® Range Force Battery Tool is a battery-powered, adjustable force installation tool for multiple application use. Its high pull force and long stroke enable installation of structural and non-structural rivets and up to 1/4" two-piece HuckBolt® fasteners\*.

\* Excludes 1/4" BOM



## Huck PR-75

A durable tool that installs plastic rivets up to 6.6 millimeters in diameter in a single stroke. Efficiently designed for one-hand operation, the PR-75 avoids breaking the rivet stem prematurely, and is able to reach areas inaccessible to level-type tools.



## Huck PR-75K

The kit includes PR-75 Quick-Set Riveter, carrying case and four rivet starter packages: 5-millimeter plastic rivets for Ford and GM applications (Huck part number 205325); 5-millimeter plastic rivets for Chrysler applications (Huck part number 205328); 6.3-millimeter plastic rivets for Chrysler, Ford and GM applications (Huck part number 205326); 6.6-millimeter plastic rivets for GM applications (Huck part number 205327).



## Huck Rivet Shaver 105-MT

The Huck® Rivet Shaver tool fits any standard size drill and burnishes 5/32", 3/16" and 1/4" shavable rivet heads to leave a clean, solid appearance that closely matches solid or brazier head rivets.



## Huck 2025

Ideal for production applications, the Huck 2025 weighs just 7.5 lbs. without the nose assembly. The 2025 installs up to 3/8" blind bolts and 1/4" lockbolts, while delivering a pull pressure of 5,290 lbs.

Note: Huck nosepieces are sold separately



## Big Daddy® Deluxe Truck Tool

The Big Daddy Deluxe Truck Tool manual riveter is a versatile and powerful hand riveter, with extra-long handles for leverage and ability to work a foot beyond natural reach. Big Daddy Deluxe Truck Tool has a patented bearing design, and a double gear reduction system. A one-piece collet case eliminates the need to adjust the tool when changing rivet diameters.



## Big Daddy Deluxe Tool Kit

KIT PART NO.	RIVET SIZE	NOSEPIECE
M39500	3/16" and 1/4"	Included

## Big Daddy Deluxe Truck Tool Nose Assemblies

KIT PART NO.	SIZE RANGE	FASTENER TYPE
M96073	3/16"	Magna-Grip
M96076	1/4"	Magna-Grip
M96079	3/16" and 1/4"	Blind Rivet

## Plastic Rivets

PART NO.	DESCRIPTION
205175	Plastic Rivet 5 mm Ford and GM (100)
205176	Plastic Rivet 6.3 mm Ford, GM, Chrysler (100)
205177	Plastic Rivet GM (100) - Size: 6.6 mm
205178	Plastic Rivet 5 mm Chrysler (100)
205325	Plastic Rivet 5 mm Ford and GM (20)
205326	Plastic Rivet 6.3 mm Ford, GM, Chrysler (20)
205327	Plastic Rivet GM (20) - Size: 6.6 mm
205328	Plastic Rivet 5 mm Chrysler (20)



## Huck Fasteners

In truck cab applications, Magna-Lok, HuckLok and Magna-Grip provide maintenance-free joints for many different components including storage compartments, vent openings, door and floor structures, skin reinforcements and firewall assembly. Using Huck lock bolts and blind fasteners reduces cost and assembly time while eliminating safety issues of welding.

## Huck Aftermarket Starter Kit - TCR-KIT

REFILL PACK QTY	DESCRIPTION CODE	DESCRIPTION AND GRIP RANGE
25	MGLP-R6-4-PKT	3/16" Steel Locking .062-.270
25	MGLP-R6-E-PKT	3/16" Steel Locking .62-.437
25	MGLP-R8-6-PKT	1/4" Steel Locking .080-.375
25	MGLP-R8-10-PKT	1/4" Steel Locking .350-.625
25	MGLP-B6-4-PKT	3/16" Aluminum Locking .62-.270
25	MGLP-B6-E-PKT	3/16" Aluminum Locking .062-.437
25	MGLP-B8-E-PKT	1/4" Aluminum Locking .080-.625

## Huck Magna-Tite Blind Rivet

25	MTP-B6-8S-PKT	3/16" Aluminum (sealant) .050-.500
25	MTP-B8-10S-PKT	1/4" Aluminum (sealant) .375-.625

## Huck Magna-Grip Pins

10	MGP98T-E6-10-PKT	3/16" Aluminum Buttonhead .062-.625
10	MGP98T-R6-10G-PKT	3/16" Steel Buttonhead .062-.625
10	MGPB-R8-10G-PKT	1/4" Steel Buttonhead .062-.625
10	MGPB-R8-20G-PKT	1/4" Steel Buttonhead .312-1.250
10	MGPT-R8-10G-PKT	1/4" Steel Truss-head .062-.625
10	MGC-R6U-PKT	3/16" Steel Standard Flange Collar
10	MGC-R8U-PKT	1/4" Steel Standard Flange Collar
10	MGCW-R6U-PKT	3/16" Steel Large Flange Collar
10	MGCW-F6-PKT	3/16" Aluminum Large Flange Collar







**HOWMET  
AEROSPACE**

# Howmet Fastening Systems

## Industrial Division Brands



Huck, Marson, Recoil, Keysert, Camloc and Simmonds are trademarks of Howmet Aerospace Inc. and/or its subsidiaries.

### North America

#### Waco Operations

PO Box 8117  
8001 Imperial Drive  
Waco, TX 76714-8117  
Tel: +1 800-388-4825  
Fax: +1 800-798-4825  
[huck.waco@howmet.com](mailto:huck.waco@howmet.com)

#### Kingston Operations

1 Corporate Drive  
Kingston, NY 12401  
Tel: +1 800-278-4825  
Fax: +1 845-334-7333  
[sales.kingston@howmet.com](mailto:sales.kingston@howmet.com)

#### Tracy Operations

1925 North MacArthur Drive  
Tracy, CA 95376  
Tel: +1 800-826-2884  
Fax: +1 800-573-2645  
[sales.idg@howmet.com](mailto:sales.idg@howmet.com)

### Global

#### Telford Operations

Unit C, Stafford Park 7  
Telford, Shropshire  
England TF3 3BQ  
Tel: +44 (0) 1952-290011  
Fax: +44 (0) 1952-290459  
[sales.telford@howmet.com](mailto:sales.telford@howmet.com)

#### Melbourne Operations

1508 Centre Road  
Clayton, Victoria  
Australia 3168  
Tel: +613-8545-3333  
Fax: +613-8545-3390  
[hfsmel.sales@howmet.com](mailto:hfsmel.sales@howmet.com)

#### Tokyo Operations (Japan & Korea)

8F CIRCLES Nihonbashi-  
Bakurocho Bldg  
1-5-12 Nihonbashi-Bakurocho  
103-0002 Tokyo Japan  
Tel: +81-3-5642-8360  
Tel: +81-3-5642-8361 x8365  
Fax: +81-3-5644-5772

#### Suzhou Operations

58 Yinsheng Road,  
SIP Suzhou, Jiangsu  
215126 China  
Tel: +86-512-62863800-8888

[hfsindustrial.com](http://hfsindustrial.com)

[YouTube.com/HFSIndustrial](https://www.youtube.com/HFSIndustrial)

The information contained in this publication is only for general guidance, and is not intended to create any warranty, express, implied, or statutory; all warranties are contained only in Howmet Fastening Systems' written quotations, acknowledgments, and/or purchase orders. It is recommended that the user secure specific, up-to-date data and information regarding each application and/or use of such products.

© 2023 Howmet Aerospace Inc. All rights reserved. HFS6118 0523  
HP-2, HP-5, HP-4x4, AH-250, are trademarks of Howmet Aerospace Inc.  
and/or its subsidiaries.