

Special features

Max. tensile strength (ultimate) 10.000 lbs / 44.482 N, rated working load 6.500 lbs / 28.913 N. The fastener is capable of absorbing high tensile loads and withstanding mechanical damage under severe operating conditions, such as shipbuilding or military applications. A unique adjustable cross pin allows for adjustable clamp lengths within a chosen grip length.

Determination of the length no. of the stud:

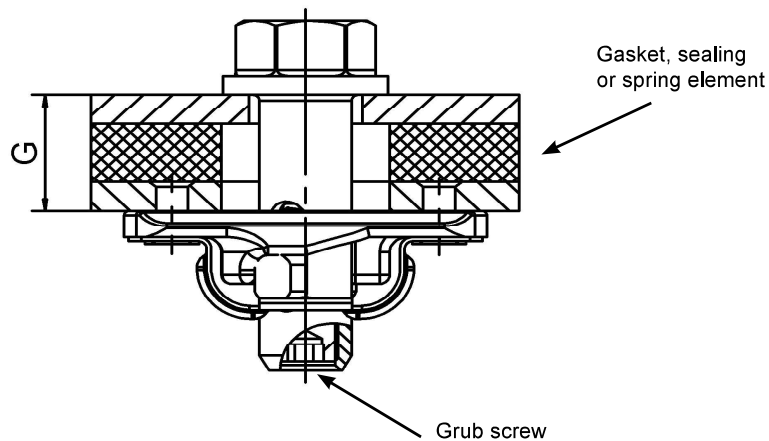

1. Determine clamping thickness „G“.

Attention: Increase the clamping thickness „G“ by the thickness of surface treatments and the compressed thickness of a gasket, sealing or spring element.

2. You will find the total clamping thickness „G“ you have determined in the left column of the following table.

3. Select the appropriate stud length in the right column.

If not using a gasket, sealing or spring element, please contact us for further information.

Stud length table

Total clamp thickness „G“	Stud Length no.
6,35 - 12,67	1
12,70 - 19,02	2
12,05 - 25,37	3
25,40 - 31,72	4
31,75 - 38,07	5
38,10 - 44,42	6
44,45 - 50,77	7

Other lengths on request.

Stud

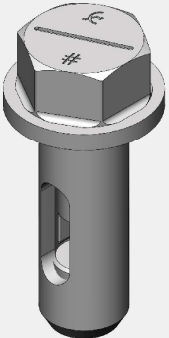
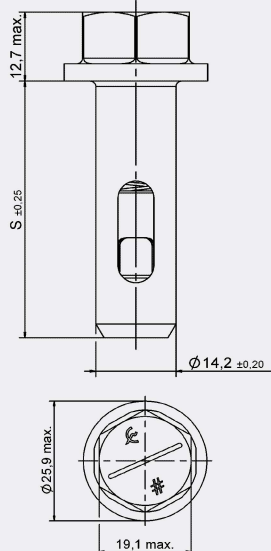
Style	Dimensions	Material / Finish	°C	Part No.
Hex Head Stud 	 <p>*S = 34,8 + (6,35 x pin length)</p>	Steel / zinc-nickel, silver, CrVI-free passivated and sealed	215	V34S01-* -1ASN

* Length no. from table, see page I-1.

Cross pin

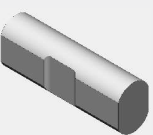
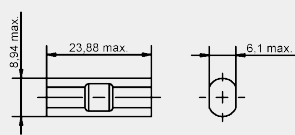
Style	Dimensions	Material / Finish	°C	Part No.
Cross Pin 		Steel / zinc-nickel, silver, CrVI-free passivated and sealed		V34S02-1-1ASN

Receptacle

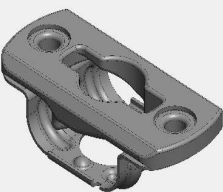
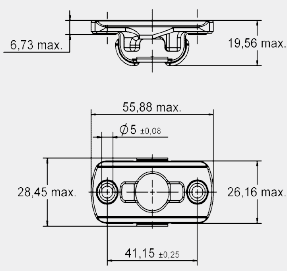
Style	Dimensions	Material / Finish	°C	Part No.
Rivet / Screw Mounting 		Steel / zinc-nickel, silver, CrVI-free passivated and sealed		V34R01-2-1BSNV

Cross pin assembly tool

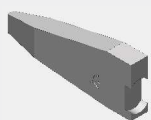
Style	Material / Finish	°C	Part No.
	stainless Steel		VT135-1-1B

Panel preparation for stud

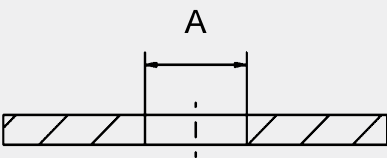
Installation dimensions					
	<table border="1"> <tr> <td>A</td> <td>17,47 mm</td> </tr> <tr> <td></td> <td>0.688 inch</td> </tr> </table>	A	17,47 mm		0.688 inch
	A	17,47 mm			
	0.688 inch				

Panel preparation for receptacle

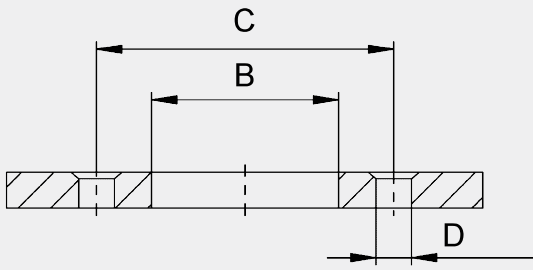
Installation dimensions					
	<table border="1"> <tr> <td>B</td> <td>25,90 mm</td> </tr> <tr> <td></td> <td>1.020 inch</td> </tr> </table>	B	25,90 mm		1.020 inch
	B	25,90 mm			
		1.020 inch			
	<table border="1"> <tr> <td>C</td> <td>41,15 mm</td> </tr> <tr> <td></td> <td>1.620 inch</td> </tr> </table>	C	41,15 mm		1.620 inch
C	41,15 mm				
	1.620 inch				
<table border="1"> <tr> <td>D</td> <td>4,93 mm</td> </tr> <tr> <td></td> <td>0.188 inch</td> </tr> </table>	D	4,93 mm		0.188 inch	
D	4,93 mm				
	0.188 inch				

Stud installation instructions

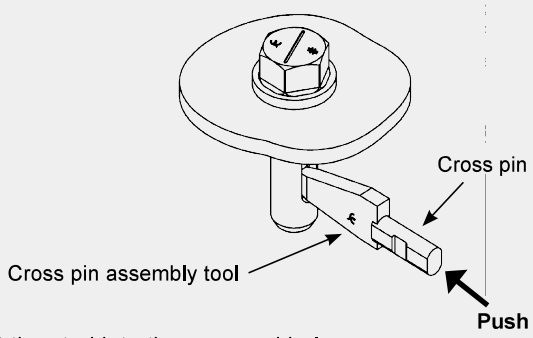
Installation	Adjustment of the cross pin
 <ol style="list-style-type: none"> 1. Insert the stud into the prepared hole. 2. Install the cross pin by using the assembly tool. 3. When the tool has been pushed completely through the stud, the cross pin will automatically lock into place. This makes the stud captive. 	<p>Adjust the cross pin by turning the grub screw (located on the underside of the the bottom of the stud) with an allen wrench (type 5) to achieve the desired clamping load.</p>