





Charge de traction maximale 500 N, charge effective 220 N

En position fermée, le mécanisme est invisible

Compensation des tolérances par système à ressort

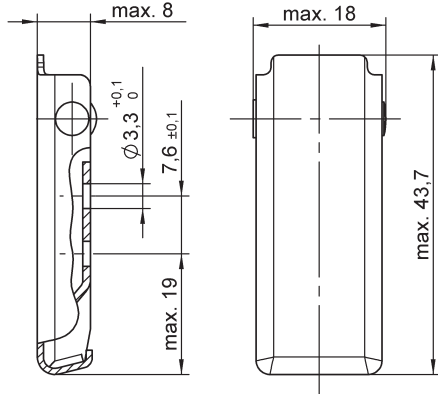
Faible encombrement

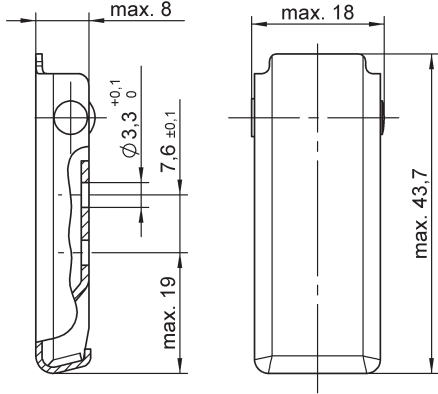
Produit	Dimensions	Matière / Finition	Référence
<p>Compensation des tolérances par crochet de fixation</p> 		Acier inoxydable	V95L07-1-1BC
<p>Compensation des tolérances par ressort</p> 		Acier / chromé Mécanisme: Acier / zingué blanc, sans CrVI, transparent passivé	V95L15-1BP

Crochet de retenue

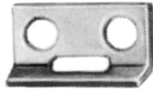
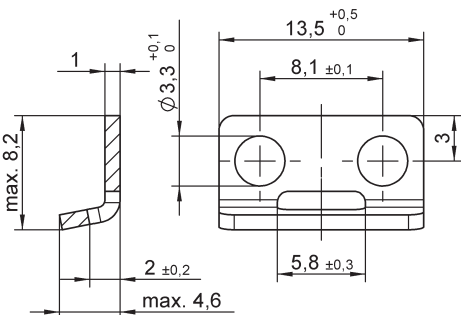
Produit	Dimensions	Matière / Finition	Référence
		Acier inoxydable	V95H07-1-1BP

Dimensions

Grenouillère avec crochet de fixation / crochet de retenue

